

The information contained in this drawing is the property of MaxStream, Inc. All rights reserved. Copyright 2000, 2001, 2002

Previous Rev.	ECO	Description

This represents a 3.3 Volt system and the signals coming from that system. Not all signals are necessary in every system.

This buffer converts the 5 V outputs from the radio down to 3.3 Volts.  
 Manufacturer: Texas Instruments  
 Part Number: SN74LVC245A

This buffer converts the 3.3 V level signals to the 5V level signals required by the radio.  
 Manufacturer: Texas Instruments  
 Part Number: SN74HC245

This DC/DC Converter (Texas Instruments TPS60110) converts 3.3 Volts to 5 Volts to supply the radio.

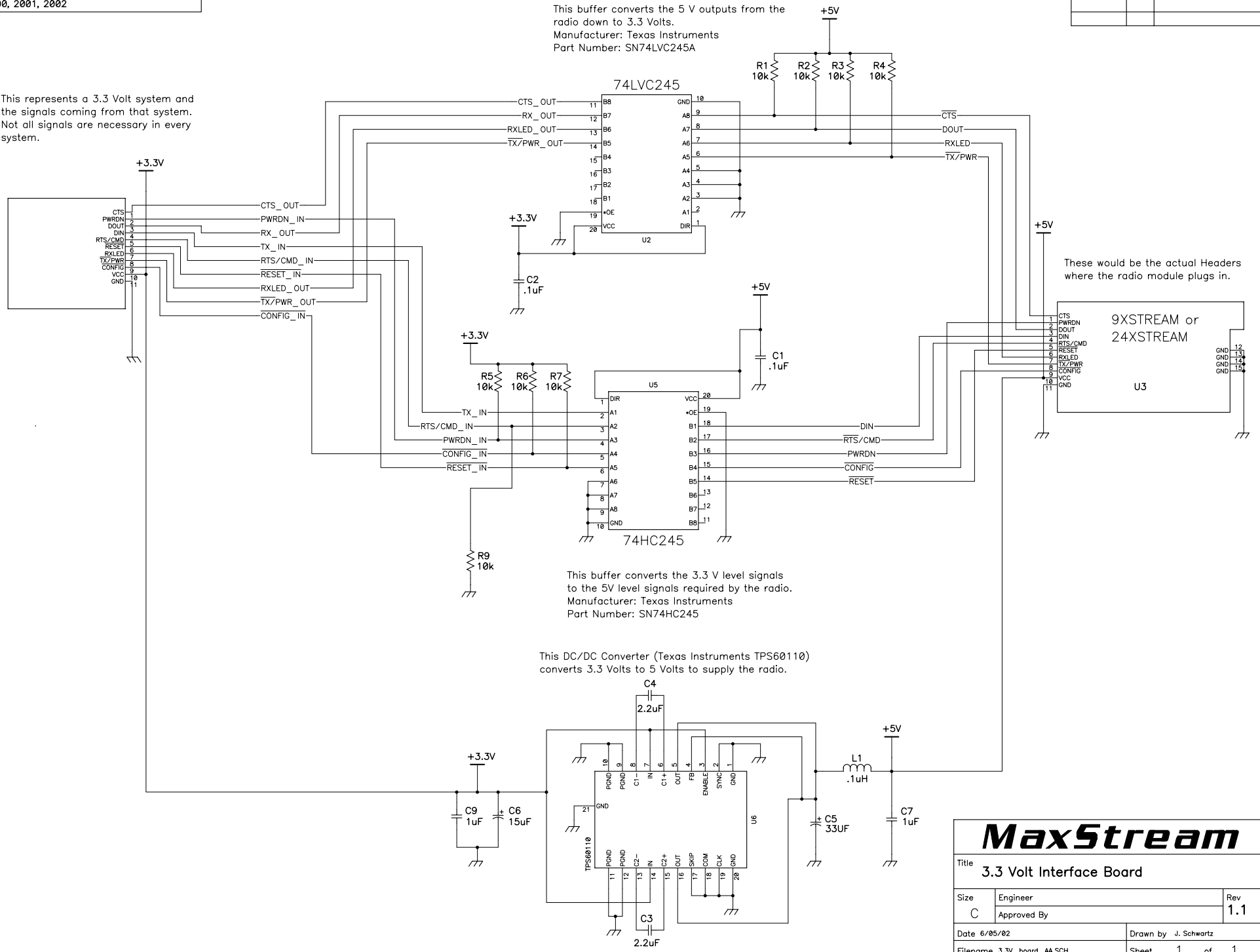

**MaxStream**

Title: **3.3 Volt Interface Board**

Size	Engineer	Rev
C	Approved By	1.1
Date	6/05/02	
Drawn by	J. Schwartz	
Filename	3.3V_board_AASCH	
Sheet	1 of 1	