

NOTES: UNLESS OTHERWISE SPECIFIED;

1. ALL RESISTOR VALUES ARE IN OHMS, 1/16W; 5%
2. ALL CAPACITORS ARE 16VDC OR HIGHER.
3. THE ORIGATION SOURCE OF A VOLTAGE IS REPRESENTED BY (▲), AND ALL REFERENCES TO THAT VOLTAGE ARE REPRESENTED BY (VCC).

4. COMPONENT IN DASHED BOX AND COMPONENT VALUES SHOWN WITH AN ASTERISK (\*) FOLLOWING THE VALUE ARE NOT NORMALLY INSTALLED.

REVISION HISTORY			REVISION APPROVAL			
REV	ECO	DESCRIPTION	PROJECT ENGINEER	APPROVAL DATE	DOCUMENT CONTROL	APPROVAL DATE
A	E12555	INITIAL RELEASE	XT	12/19/03	KF	12/22/03

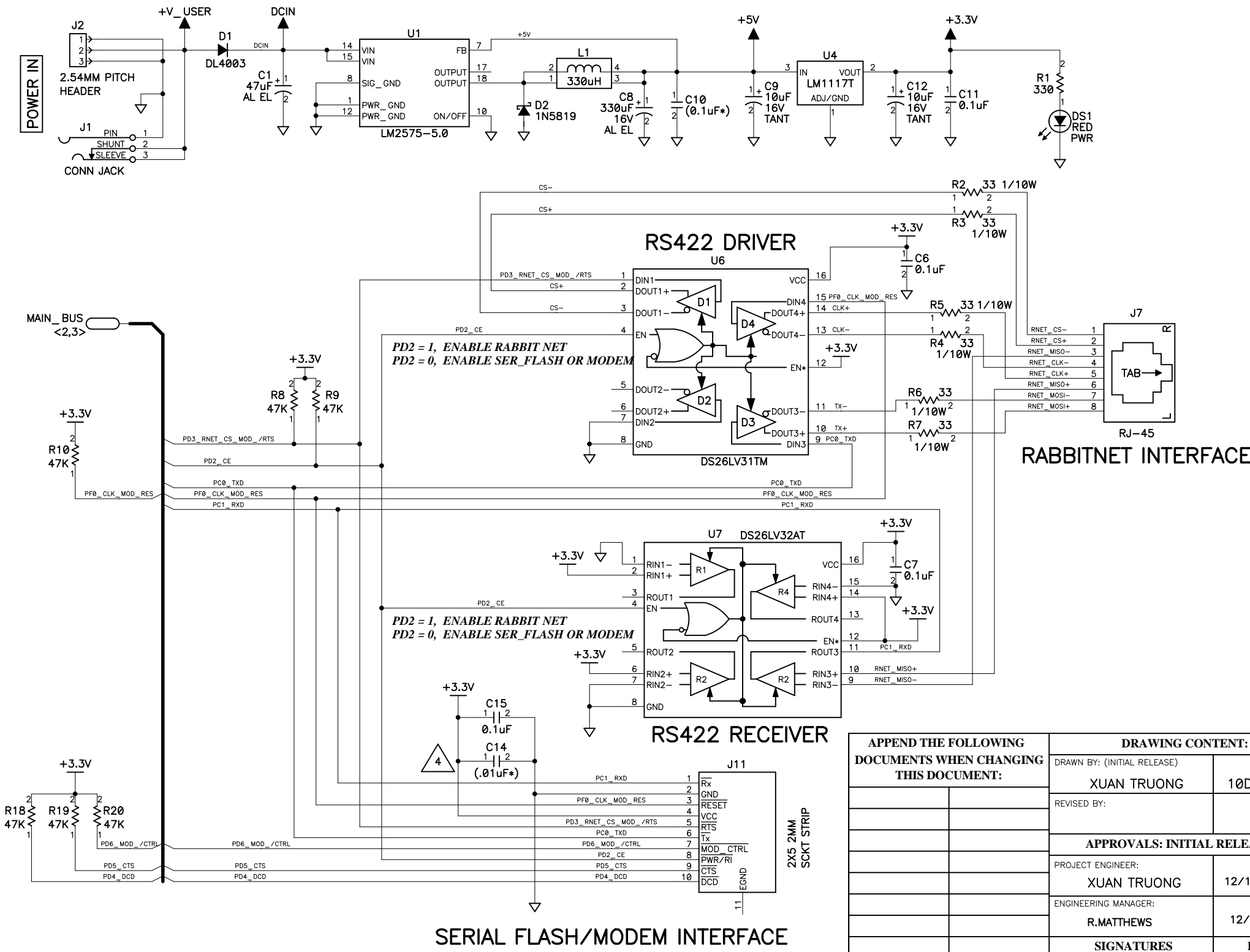

Power Table						
Ref Des	Device(Type)	Package	GND	+5V	+3.3V	DCIN
U1	661-0015	S024W	10,8,1,12	7		15,14
U2	660-0205	DIP16		16		
U3	660-0205	DIP16		16		
U4	661-0044	T0252	1	3	2	
U5	616-0574	TSSOP20	10	20		
U6	660-0183	SO16	7,8		16,12	
U7	660-0182	SO16	1,7,8,15		2,6,12,16,14	
U8	616-0574	TSSOP20	10	20		
U9	660-0175	SO16	15		16	
U10	660-0196	SO8	2,5		8	
U11	660-0177	TSSOP20	7,6,9,8,10		1,20	
U12	660-0177	TSSOP20	10		20	

COPYRIGHT 2003, Z-WORLD, INC.

APPEND THE FOLLOWING DOCUMENTS WHEN CHANGING THIS DOCUMENT:	DRAWING CONTENT:	
	DRAWN BY: (INITIAL RELEASE)	XUAN TRUONG 10DEC03
	REVISED BY:	
	APPROVALS: INITIAL RELEASE	
	PROJECT ENGINEER:	XUAN TRUONG 12/19/03
	ENGINEERING MANAGER:	R.MATTHEWS 12/22/03
	SIGNATURES	DATE

TITLE

# SCHEMATIC DIAGRAM RCM3300 DEVELOPMENT BOARD

SIZE **B** DWG NO. 090-0188

SCALE NONE RELEASE DATE SHEET 1 OF 3



2900 SPAFFORD ST.  
DAVIS, CA 95616  
530 - 757 - 4616

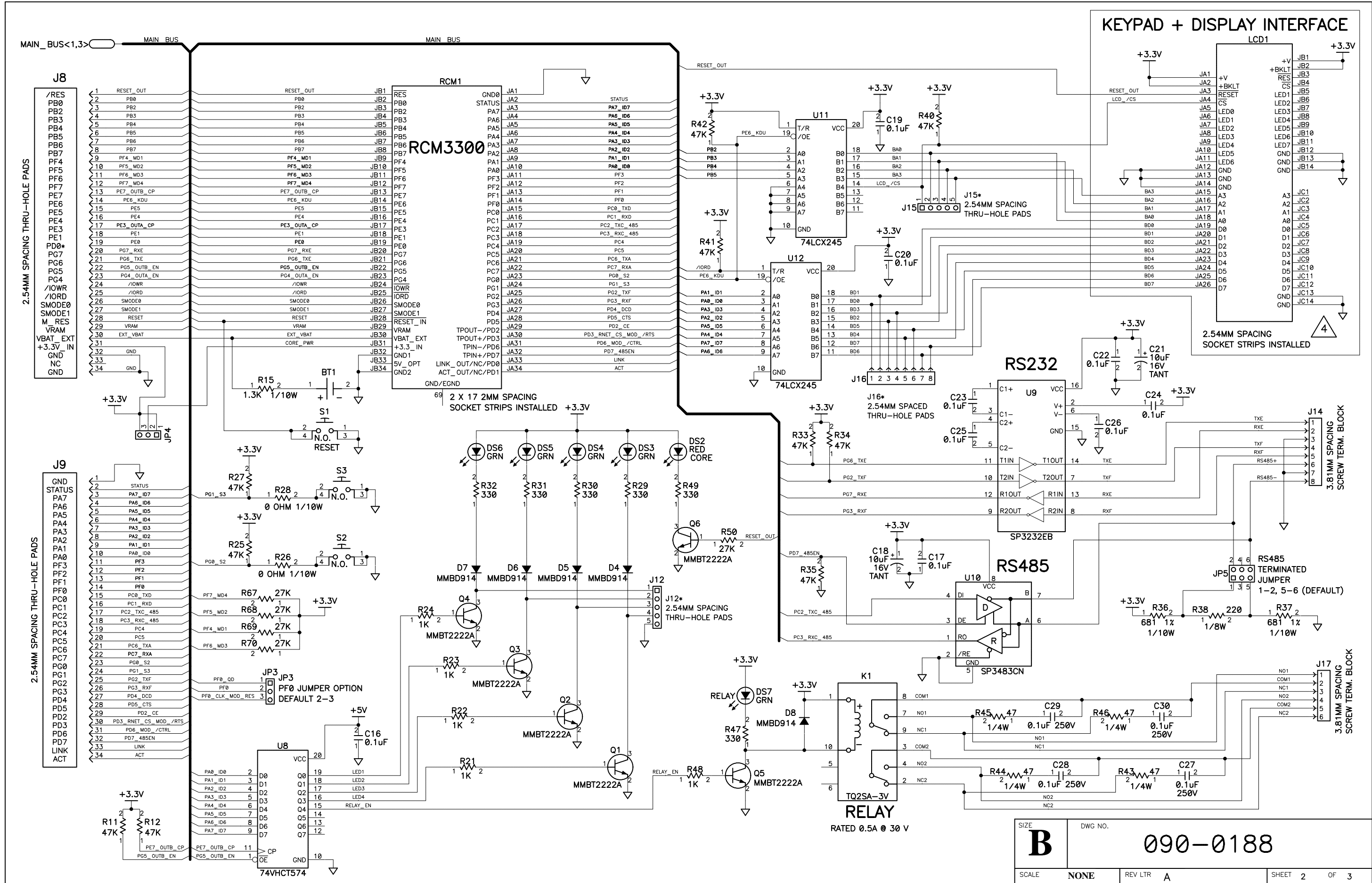

SIZE	DWG NO.
<b>B</b>	090-0188
SCALE	REV LTR
NONE	A
SHEET 2	OF 3

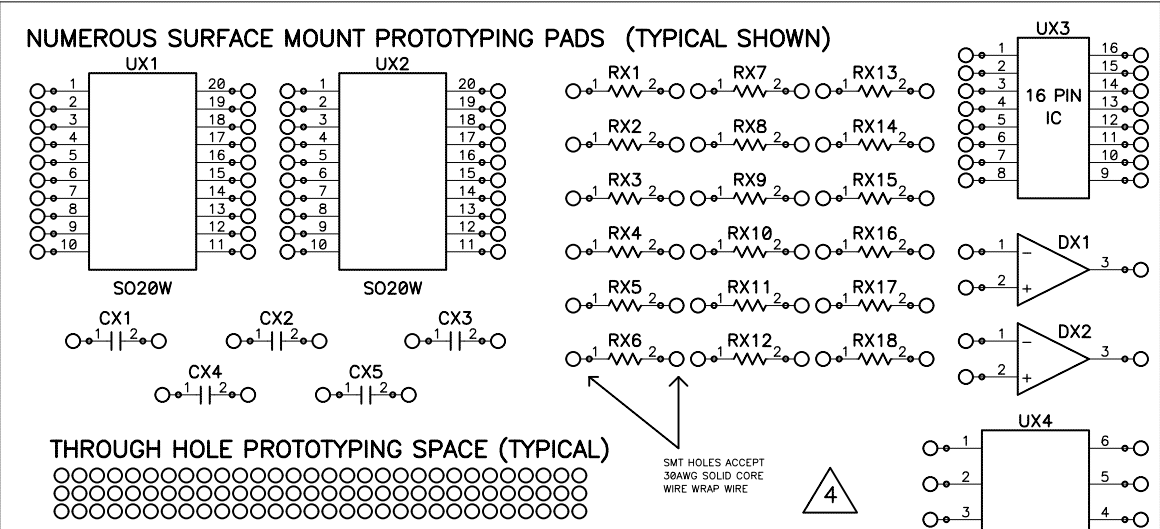
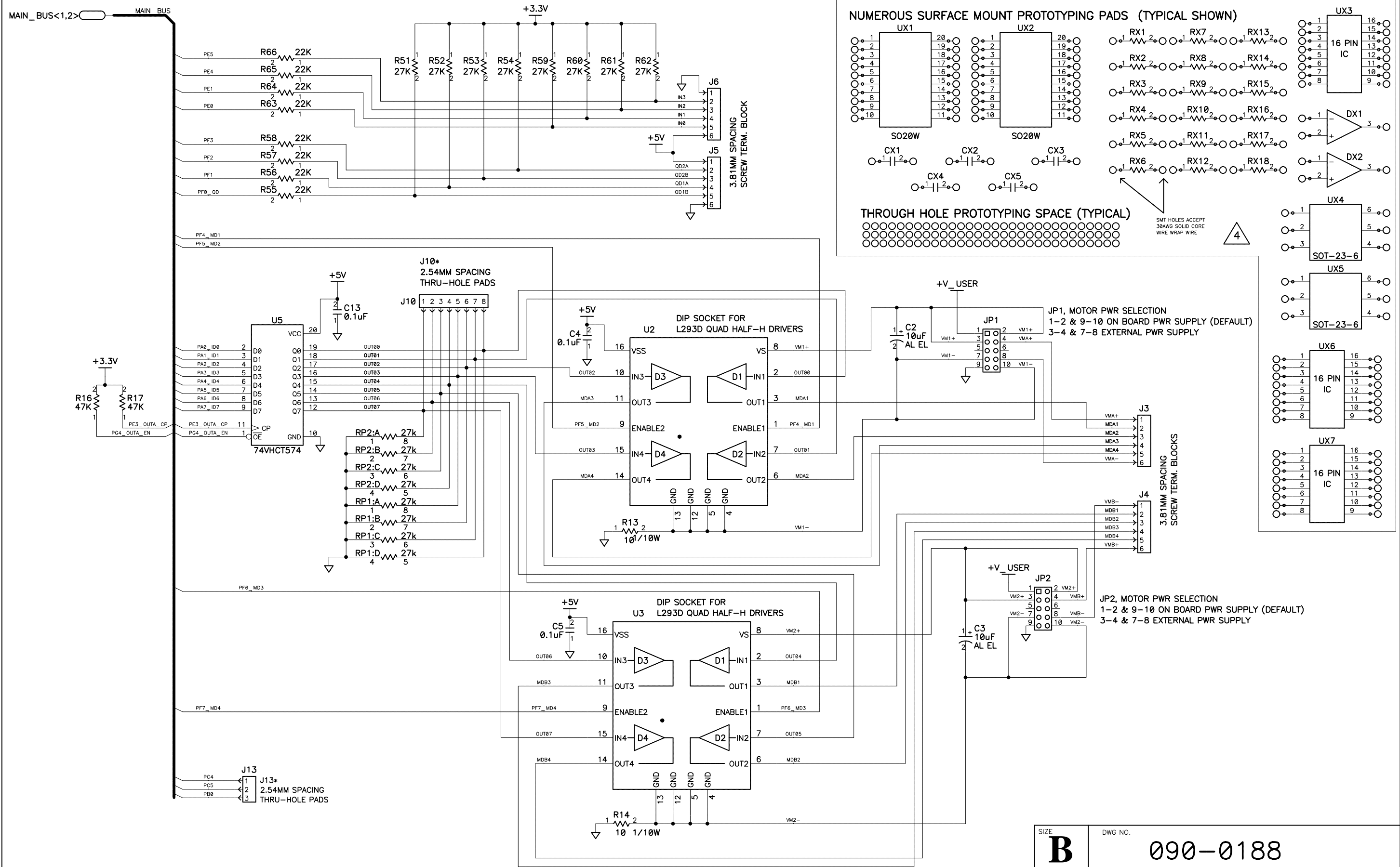

SIZE <b>B</b>	DWG NO. <b>090-0188</b>
SCALE NONE	REV LTR A
SHEET <b>3</b> OF <b>3</b>	