

Notes

This board allows the user to test all of the features of the XBee TH modules.

The following peripherals are used on this board to test different features:

- USB-C Connector
 - Powers the whole board with 5V
 - Provides a simple UART communication with the module that is compatible with XCTU
 - Dip switches are provided on each UART line from the USB which allows the user to disconnect any of these lines if he/she wants to test the UART lines with other peripherals
- Battery Connector
 - Can power the whole board with 2V to 5V so long as the USB-C Connector is not plugged in
 - This allows the user to easily power the module in a portable setting
- XBee Current Measurement
 - Allows the user to measure the current draw of the XBee in any mode
 - Easy to use interface: Switch the current measure switch to the "Active" position and place a current meter probe across the current measure header
- LEDs
 - LED indicators for the following lines: UART DOUT, UART DIN, ON/#SLP/DIO9, Conn Status/DIO5, and RSSI/PWM0/DIO10
 - Allows the user to easily test the GPIOs
- Buttons
 - Buttons for the following lines: Reset and Comm/AD0/DIO0
 - Allows the user to easily reset and commission the XBee module
- Grove Connector
 - Grove connector connects to pins 32 and 8 on the XBee module
 - This allows for I2C, ADC, and DIO testing on the Grove.
- Breakout Connector
 - 40-pin external header that connects to power, ground, and each XBee pin
 - This allows the user to connect to any XBee pin easily to test the XBee with other peripherals

PCB and Stencil

PCB1



Rubber Feet

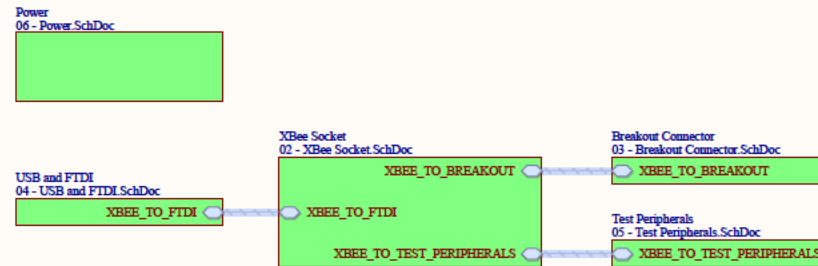
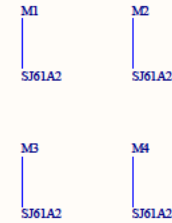

Title Block Diagram		Digi International	
Variation 55002008-01	Revision A		
Engineer	Sheet 1 of 6		
Description PCA_XBIB USB-C SMT Base			

XBee SMT Socket

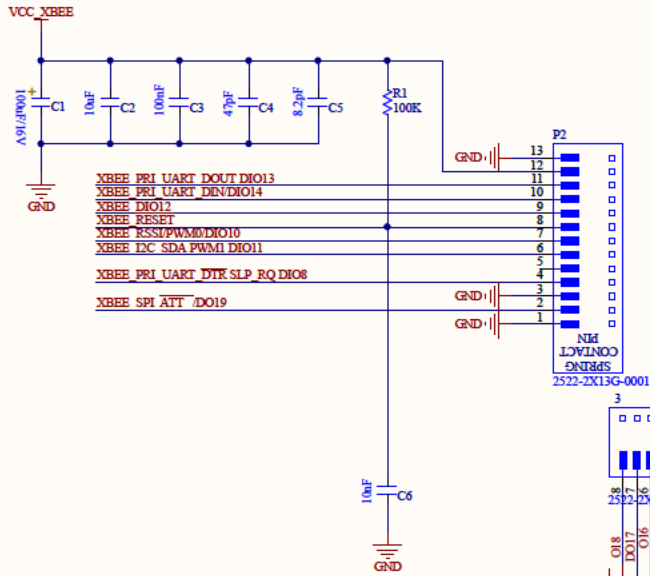

Direct USB

This section is not populated.

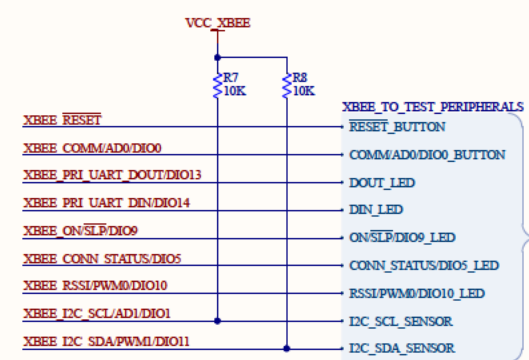
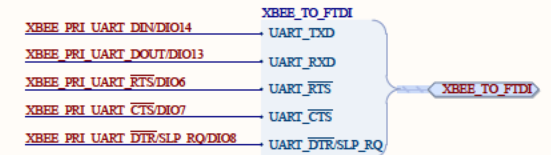
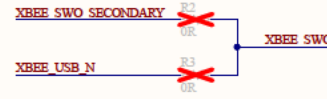
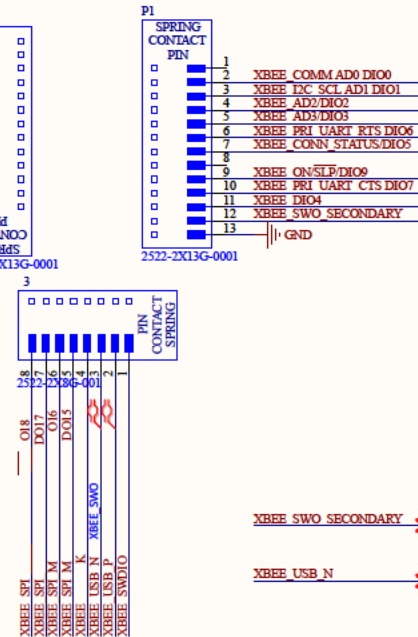
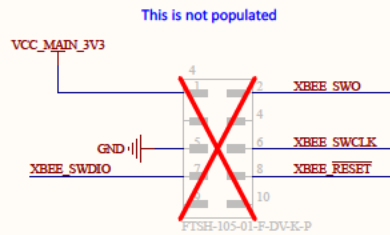
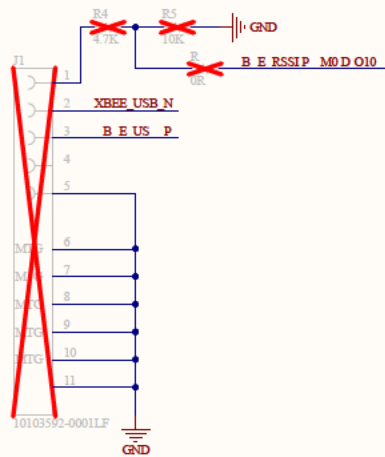

Breakout Connector

The Breakout Connector is connected to every pin on the XBee module and allows the user to test the pins on separate boards.

XBEE_TO_BREAKOUT_CONNECTOR	XBEE PRI UART DOUT/DIO13
PRI_UART_DOUT/DIO13	XBEE PRI UART DOUT/DIO13
PRI_UART_DIN/DIO14	XBEE PRI UART DIN/DIO14
PRI_UART_RTS/DIO6	XBEE PRI UART RTS/DIO6
PRI_UART_CTS/DIO7	XBEE PRI UART CTS/DIO7
PRI_UART_DTR/SLP_RQ/DIO8	XBEE PRI UART DTR/SLP_RQ/DIO8
SPI_MISO/SEC_UART_TXD/DO16	XBEE SPI MISO/SEC_UART_TXD/DO16
SPI_MISO/SEC_UART_RXD/DO15	XBEE SPI MISO/SEC_UART_RXD/DO15
SPI_CLK/SEC_UART_RTS/DO18	XBEE SPI CLK/SEC_UART_RTS/DO18
SPI_SSEL/SEC_UART_CTS/DO17	XBEE SPI SSEL/SEC_UART_CTS/DO17
SPI_ATTn/DO19	XBEE SPI ATTn/DO19
I2C_SDA/PWM1/DIO11	XBEE I2C SDA/PWM1/DIO11
I2C_SCL/AD1/DIO1	XBEE I2C_SCL/AD1/DIO1
COMM/AD0/DIO0	XBEE COMM/AD0/DIO0
AD2/DIO2	XBEE AD2/DIO2
AD3/DIO3	XBEE AD3/DIO3
DIO4	XBEE DIO4
CONN_STATUS/DIO5	XBEE CONN_STATUS/DIO5
ON_SLP/DIO9	XBEE ON_SLP/DIO9
RSSI/PWM0/DIO10	XBEE RSSI/PWM0/DIO10
DIO12	XBEE DIO12
RESET	XBEE RESET

XBEE_TO_BREA UT

Primary UART
 SPI and Secondary UART
 I2C
 General GPIO

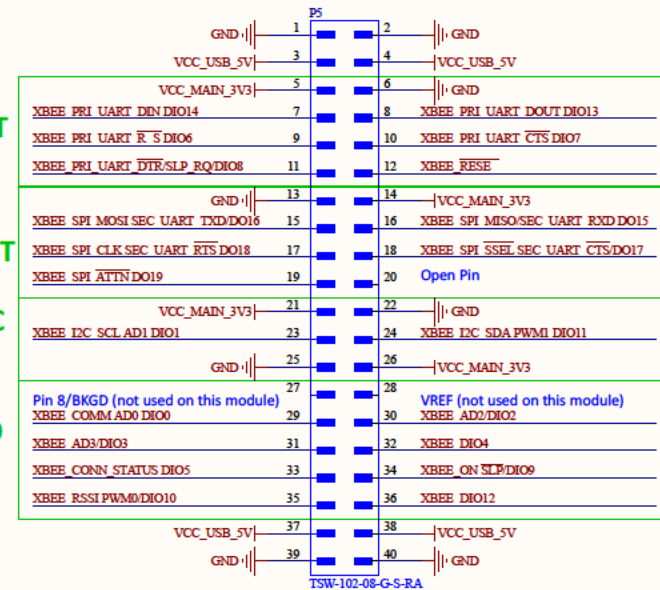

USB Type C Connector

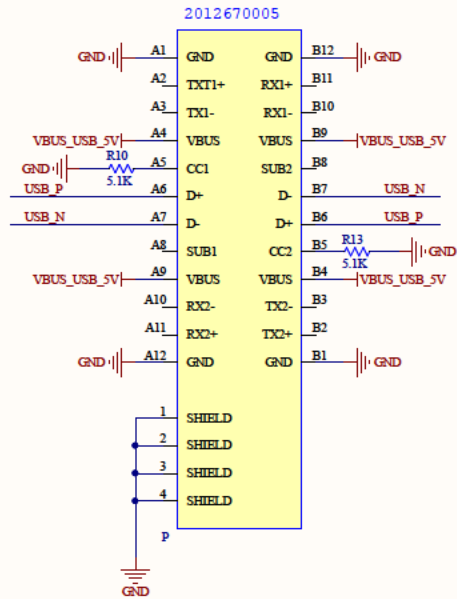

FT232R FTDI Chip (USB to UART)

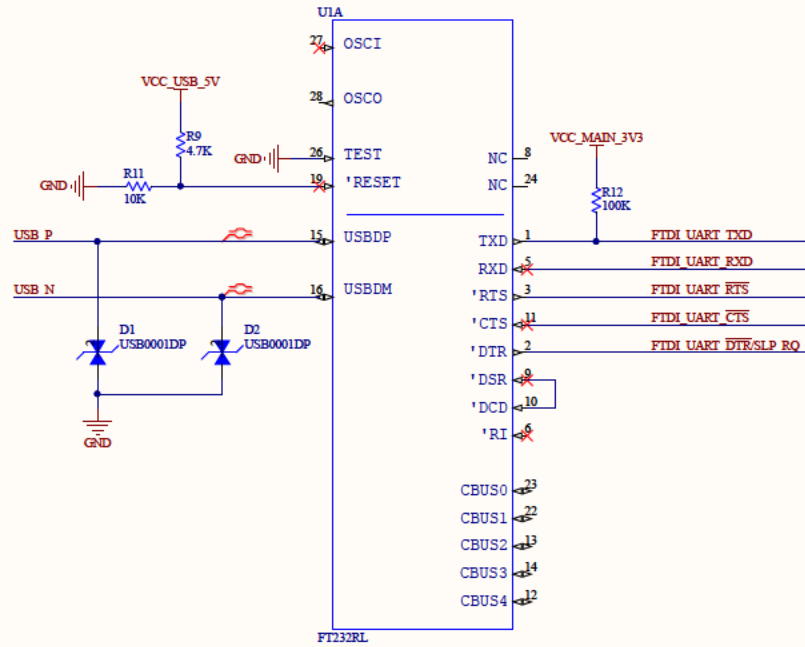

FTDI Dip Switch

This dip switch allows the user to disconnect any of the primary UART lines on the XBee from the FTDI chip. This allows for any testing on the primary UART lines without the FTDI chip interfering.

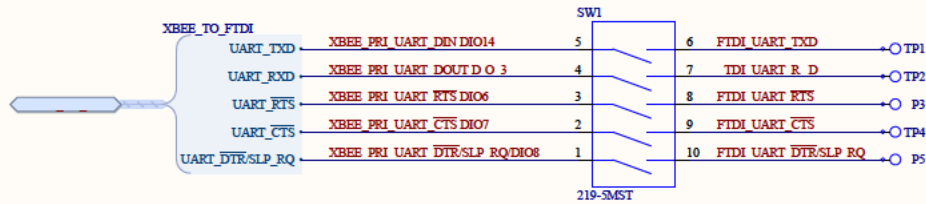

Title USB and FTDI		Digi International
Variation 55002008-01	Revision A	
Engineer	Sheet 4 of 6	
Description PCA_XBIB USB-C SMT Base		

LEDs

XBEE_TO_TEST_PERIPHERALS	XBEE_RESET
RESET_BUTTON	XBEE_RESET
COMM/AD0/DIO0_BUTTON	XBEE_COMM/AD0/DIO0
DOUT_LED	XBEE_PRI_UART_DOUT/DIO13
DIN_LED	XBEE_PRI_UART_DIN/DIO14
ON/SLP/DIO9_LED	XBEE_ON/SLP/DIO9
CONN_STATUS/DIO5_LED	XBEE_CONN_STATUS/DIO5
RSSI/PWM0/DIO10_LED	XBEE_RSSI/PWM0/DIO10
I2C_SCL_SENSOR	XBEE_I2C_SCL/AD1/DIO1
I2C_SDA_SENSOR	XBEE_I2C_SDA/PWM1/DIO11

XBEE_TO_TEST_PERIPHERALS

Buttons

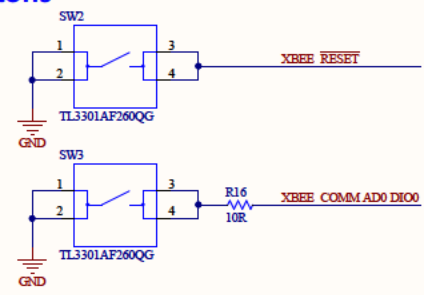

I2C Grove Connector and Sensor

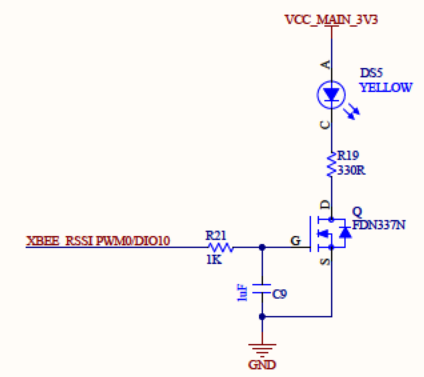
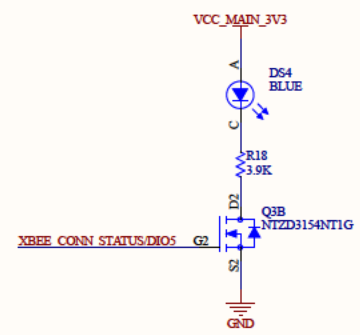
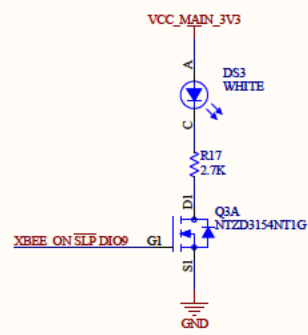
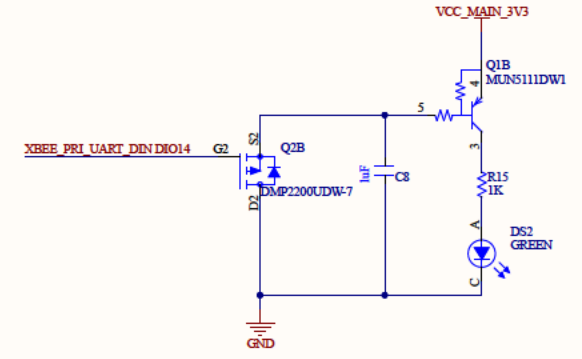
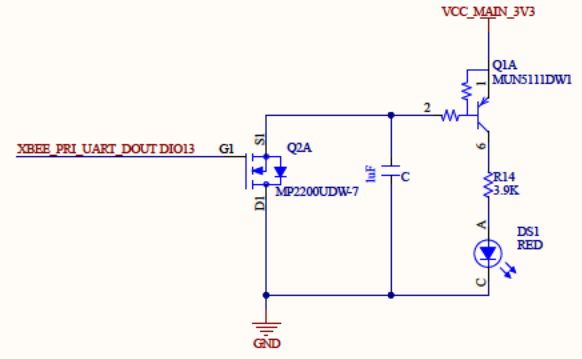
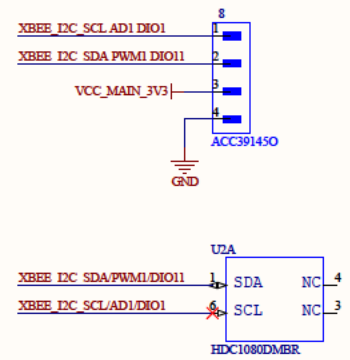

Title Test Peripherals		Digi International		
Variation 55002008-01	Revision A			
Engineer	Sheet 5 of 6			
Description PCA_XBIB USB-C SMT Base				

3.3V Supply

The supply on the development board will either come from the USB connection or from a battery connection
 If both are plugged in, the USB will power the board
 The battery will plug into the P3 header and can range from 2V to 5V

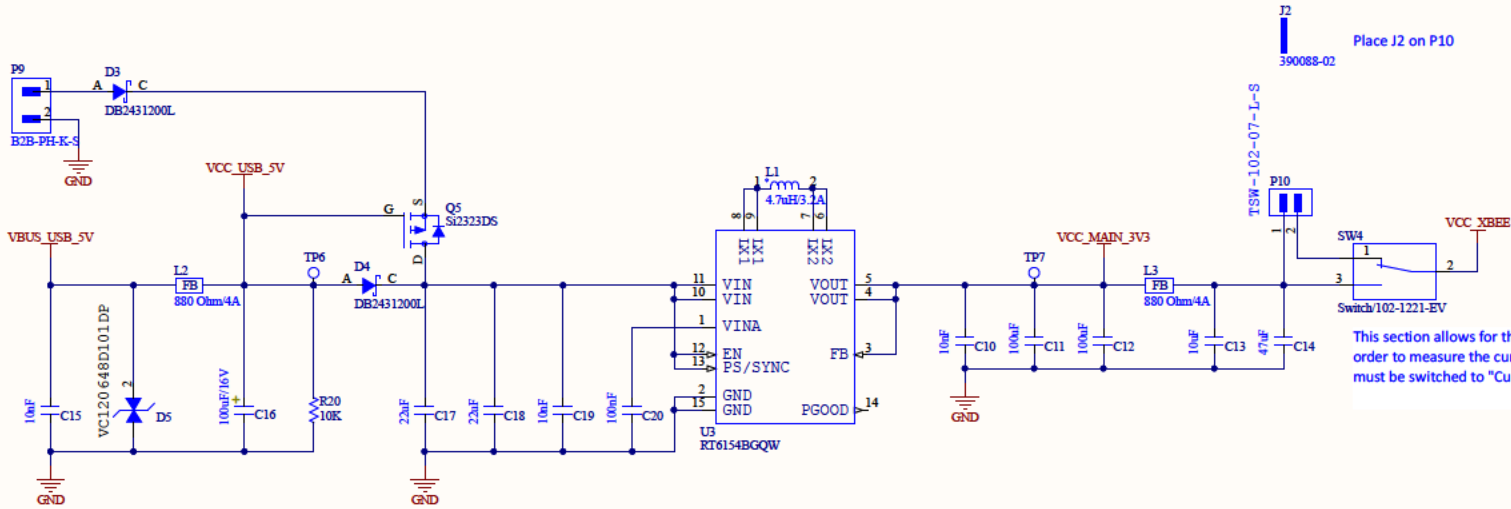

Place J2 on P10

This section allows for the user to measure the current draw on the XBee. In order to measure the current, a current probe must be placed on P10 and SW4 must be switched to "Current Measure" setting.

IC Power

