

ENGINEERING TEST REPORT

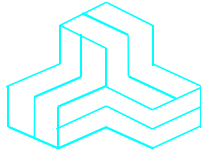

XBee3
Model: XBEE3, HVIN: XBEE3
IC: 1846A-XBEE3

Applicant:

Digi International Inc
9350 Excelsior Blvd. Suite 700
Hopkins, MN 55343
USA

In Accordance With

Industry Canada, RSS-247, Issue 2
Digital Transmission Systems (DTSS), Frequency Hopping Systems (FHSs) and
Licence-Exempt Local Area Network (LE-LAN) Devices

UltraTech's File No.: 19DIGI159_ICRSS247Z

This Test report is Issued under the Authority of
Tri M. Luu
Vice President of Engineering
UltraTech Group of Labs

Date: December 16, 2019

Report Prepared by: Dan Huynh

Tested by: Hung Trinh

Issued Date: December 16, 2019

Test Dates:
September 27, 2019
October 2 & 3, 2019

- *The results in this Test Report apply only to the sample(s) tested, and the sample tested is randomly selected.*
- *This report must not be used by the client to claim product endorsement by any agency of the US Government.*
- *This test report shall not be reproduced, except in full, without a written approval from UltraTech*

UltraTech

3000 Bristol Circle, Oakville, Ontario, Canada L6H 6G4
Tel.: (905) 829-1570 Fax.: (905) 829-8050
Website: www.ultratech-labs.com, Email: vic@ultratech-labs.com, Email: tri@ultratech-labs.com



APEC TEL CA0001



1309



CA 0001/2049



AT-1945



SL2-IN-E-1119R



Korea KCC-RRR
CA2049

TABLE OF CONTENTS

EXHIBIT 1. INTRODUCTION..... 1

1.1. SCOPE 1

1.2. RELATED SUBMITTAL(S)/GRANT(S) 1

1.3. NORMATIVE REFERENCES 1

EXHIBIT 2. PERFORMANCE ASSESSMENT 2

2.1. CLIENT INFORMATION 2

2.2. EQUIPMENT UNDER TEST (EUT) INFORMATION 2

2.3. EUT'S TECHNICAL SPECIFICATIONS..... 3

2.4. ASSOCIATED ANTENNA DESCRIPTIONS 3

2.5. LIST OF EUT'S PORTS (USB XBee3 Adatpter)..... 3

2.6. ANCILLARY EQUIPMENT 3

EXHIBIT 3. EUT OPERATING CONDITIONS AND CONFIGURATIONS DURING TESTS 4

3.1. CLIMATE TEST CONDITIONS 4

3.2. OPERATIONAL TEST CONDITIONS & ARRANGEMENT FOR TESTS..... 4

EXHIBIT 4. SUMMARY OF TEST RESULTS..... 5

4.1. LOCATION OF TESTS 5

4.2. APPLICABILITY & SUMMARY OF EMC EMISSION TEST RESULTS 5

4.3. MODIFICATIONS INCORPORATED IN THE EUT FOR COMPLIANCE PURPOSES 5

EXHIBIT 5. TEST DATA 6

5.1. TRANSMITTER OUTPUT POWER AND EIRP [RSS-247, SECTION 5.4] 6

5.2. UNWANTED EMISSIONS (RADIATED) [RSS-247, SECTION 5.5] 10

5.3. EXPOSURE OF HUMANS TO RF FIELD [RSS-Gen, SECTION 3.4 & RSS-102] 20

EXHIBIT 6. TEST EQUIPMENT LIST 21

EXHIBIT 7. MEASUREMENT UNCERTAINTY 22

7.1. RADIATED EMISSION MEASUREMENT UNCERTAINTY 22

EXHIBIT 1. INTRODUCTION

1.1. SCOPE

Reference:	Industry Canada RSS-247, Issue 2
Title:	Digital Transmission Systems (DTSS), Frequency Hopping Systems (FHSs) and Licence-Exempt Local Area Network (LE-LAN) Devices
Purpose of Test:	Class II Permissive Change: <ul style="list-style-type: none"> ▪ Add additional antenna to the approved antennas list
Test Procedures:	<ul style="list-style-type: none"> ▪ ANSI C63.4 ▪ FCC KDB Publication No. 558074 D01 15.247 Meas Guidance v05r02 ▪ RSS-247, Issue 2; RSS-Gen, Issue 5
Environmental Classification:	<input checked="" type="checkbox"/> Commercial, industrial or business environment <input type="checkbox"/> Residential environment

1.2. RELATED SUBMITTAL(S)/GRANT(S)

None.

1.3. NORMATIVE REFERENCES

Publication	Year	Title
RSS-Gen, Issue 5 Amendment 1	2018 2019	General Requirements for Compliance of Radio Apparatus
RSS-247, Issue 2	2017	Digital Transmission Systems (DTSS), Frequency Hopping Systems (FHSs) and Licence-Exempt Local Area Network (LE-LAN) Devices
RSS-102, Issue 5	2015	Radio Frequency (RF) Exposure Compliance of Radiocommunication Apparatus (All Frequency Bands)
ICES-003, Issue 6	2016	Information Technology Equipment (Including Digital Apparatus) - Limits and Methods of Measurement
47 CFR Parts 0-19	2019	Code of Federal Regulations (CFR), Title 47 – Telecommunication
ANSI C63.4	2014	American National Standard for Methods of Measurement of Radio-Noise Emissions from Low-Voltage Electrical and Electronic Equipment in the Range of 9 kHz to 40 GHz
ANSI C63.10	2013	American National Standard of Procedures for Compliance Testing of Unlicensed Wireless Devices
FCC, KDB Publication No. 558074 D01 15.247 Meas Guidance v05r02	2019	GUIDANCE FOR COMPLIANCE MEASUREMENTS ON DIGITAL TRANSMISSION SYSTEM, FREQUENCY HOPPING SPREAD SPECTRUM SYSTEM, AND HYBRID SYSTEM DEVICES OPERATING UNDER SECTION 15.247 OF THE FCC RULES

EXHIBIT 2. PERFORMANCE ASSESSMENT

2.1. CLIENT INFORMATION

Applicant	
Name:	Digi International Inc
Address:	9350 Excelsior Blvd. Suite 700 Hopkins, MN 55343 USA
Contact Person:	Scott Wilken Phone #:(952) 912-4965 Fax #: (952) 912-4952 Email Address: scott.wilken@digi.com

Manufacturer	
Name:	Digi International Inc
Address:	9350 Excelsior Blvd. Suite 700 Hopkins, MN 55343 USA
Contact Person:	Scott Wilken Phone #:(952) 912-4965 Fax #: (952) 912-4952 Email Address: scott.wilken@digi.com

2.2. EQUIPMENT UNDER TEST (EUT) INFORMATION

The following information (with the exception of the Date of Receipt) has been supplied by the applicant.

Brand Name:	Digi International Inc
Product Name:	XBee3
Model Name or Number:	XBEE3
Serial Number:	Test Sample
Type of Equipment:	Digital Transmission System (DTS)
Input Power Supply Type:	External DC Power Supply
Primary User Functions of EUT:	802.15.4 connectivity of embedded systems, BLE connectivity

2.3. EUT'S TECHNICAL SPECIFICATIONS

Transmitter	
Equipment Type:	Mobile Base station (fixed use)
Intended Operating Environment:	Commercial, industrial or business environment
Power Supply Requirement:	3.3V (nominal)
RF Output Power Rating:	19.44 dBm Maximum Peak (87.90 mW)
Operating Frequency Range:	2405 - 2480 MHz
RF Output Impedance:	50 Ω
Duty Cycle:	Continuous
Modulation Type:	QPSK
Antenna Connector Types:	Integral antenna, U.FL, RF Pad

2.4. ASSOCIATED ANTENNA DESCRIPTIONS

Manufacturer	Antenna Type	P/N	Maximum Gain (dBi)
Taoglas	Patch	FXP74.07.0100A	4

2.5. LIST OF EUT'S PORTS (USB XBee3 Adatpter)

Port Number	EUT's Port Description	Number of Identical Ports	Connector Type	Cable Type (Shielded/Non-shielded)
1	RF port	1	Integral antenna, U.FL or RF Pad	Shielded cable (N/A for integral antenna)
2	DC supply and I/O port	1	Castellated Pads	Direct connection (no cable)

2.6. ANCILLARY EQUIPMENT

The EUT was tested while connected to the following representative configuration of ancillary equipment necessary to exercise the ports during tests:

Ancillary Equipment # 1	
Description:	Test Jig
Brand name:	Digi International
Model Name or Number:	N/A
Serial Number:	N/A
Connected to EUT's Port:	Module pin signals

EXHIBIT 3. EUT OPERATING CONDITIONS AND CONFIGURATIONS DURING TESTS

3.1. CLIMATE TEST CONDITIONS

The climate conditions of the test environment are as follows:

Temperature:	21 to 23 °C
Humidity:	45 to 58%
Pressure:	102 kPa
Power Input Source:	3.6 VDC from Test Jig

3.2. OPERATIONAL TEST CONDITIONS & ARRANGEMENT FOR TESTS

Operating Modes:	The transmitter was operated in a continuous transmission mode with the carrier modulated as specified in the Test Data.
Special Test Software:	Test software provided by the Applicant to operate the EUT at each channel frequency continuously and in the range of typical modes of operation.
Special Hardware Used:	Test Jig
Transmitter Test Antenna:	The EUT is tested with the antenna fitted in a manner typical of normal intended use as integral as described with the test results.

Transmitter Test Signals	
Frequency Band(s):	2405 - 2480 MHz
Frequency(ies) Tested:	2405 MHz, 2440 MHz, 2475 MHz, 2480 MHz
RF Power Output: (measured maximum output power at antenna terminals)	19.44 dBm Maximum Peak (87.90 mW)
Normal Test Modulation:	QPSK
Modulating Signal Source:	Internal

EXHIBIT 4. SUMMARY OF TEST RESULTS

4.1. LOCATION OF TESTS

All of the measurements described in this report were performed at Ultratech Group of Labs located in the city of Oakville, Province of Ontario, Canada.

- AC Power Line Conducted Emissions were performed in UltraTech's shielded room, 24'(L) by 16'(W) by 8'(H).
- Radiated Emissions were performed at the Ultratech's 3-10 TDK Semi-Anechoic Chamber situated in the Town of Oakville, province of Ontario. This test site been calibrated in accordance with ANSI C63.4, and found to be in compliance with the requirements of Sec. 2.948 of the FCC Rules. The descriptions and site measurement data of the Oakville 3-10 TDK Semi-Anechoic Chamber has been filed with ANAB File No.: AT-1945.

4.2. APPLICABILITY & SUMMARY OF EMC EMISSION TEST RESULTS

ISED Rules	Test Requirements	Compliance (Yes/No)
RSS-Gen, Section 6.4	External Controls	Yes
RSS-Gen, Section 3.4 and RSS-102	Radio Frequency Exposure	Yes
RSS-Gen, Section 7.3	Receiver Radiated Emissions	N/A
RSS-Gen, Section 7.4	Receiver Conducted Emissions	N/A
RSS-Gen, Section 8.8	AC Power Line Conducted Emissions	N/A
ICES-003, Issue 6	Information Technology Equipment (Including Digital Apparatus) - Limits and Methods of Measurement	N/A
RSS-247, Section 5.2(a)	6 dB Bandwidth	N/A
RSS-247, Section 5.2(b)	Transmitter Power Spectral Density	N/A
RSS-247, Section 5.4	Transmitter Output Power and e.i.r.p.	Yes
RSS-247, Section 5.5	Unwanted Emissions	Yes

4.3. MODIFICATIONS INCORPORATED IN THE EUT FOR COMPLIANCE PURPOSES

None.

EXHIBIT 5. TEST DATA

5.1. TRANSMITTER OUTPUT POWER AND EIRP [RSS-247, SECTION 5.4]

5.1.1. Limit(s)

Section 5.4(d): For DTSs employing digital modulation techniques operating in the bands 902-928 MHz and 2400-2483.5 MHz, the maximum peak conducted output power shall not exceed 1W. The e.i.r.p. shall not exceed 4 W, except as provided in section 5.4(e).

5.1.2. Method of Measurements & Test Arrangement

KDB 558074 D01 15.247 Meas Guidance v05r02, Section 8.3.1.1 RBW ≥ DTS bandwidth

5.1.3. Test Arrangement

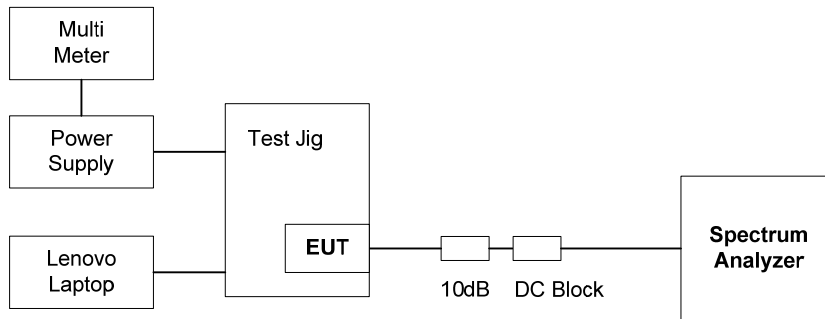

5.1.4. Test Data

Maximum Peak Conducted Power

Modulation	Power Setting	Channel	Frequency (MHz)	Maximum Peak Conducted Power (dBm)	Peak Power Limit (dBm)
QPSK	20	11	2405	19.44	30
		18	2440	19.37	30
		25	2475	19.41	30
	16	26	2480	15.75	30

Plot 5.1.4.1. Maximum Peak Conducted Output Power, QPSK Modulation, Power Setting 20, Ch 11, 2405 MHz

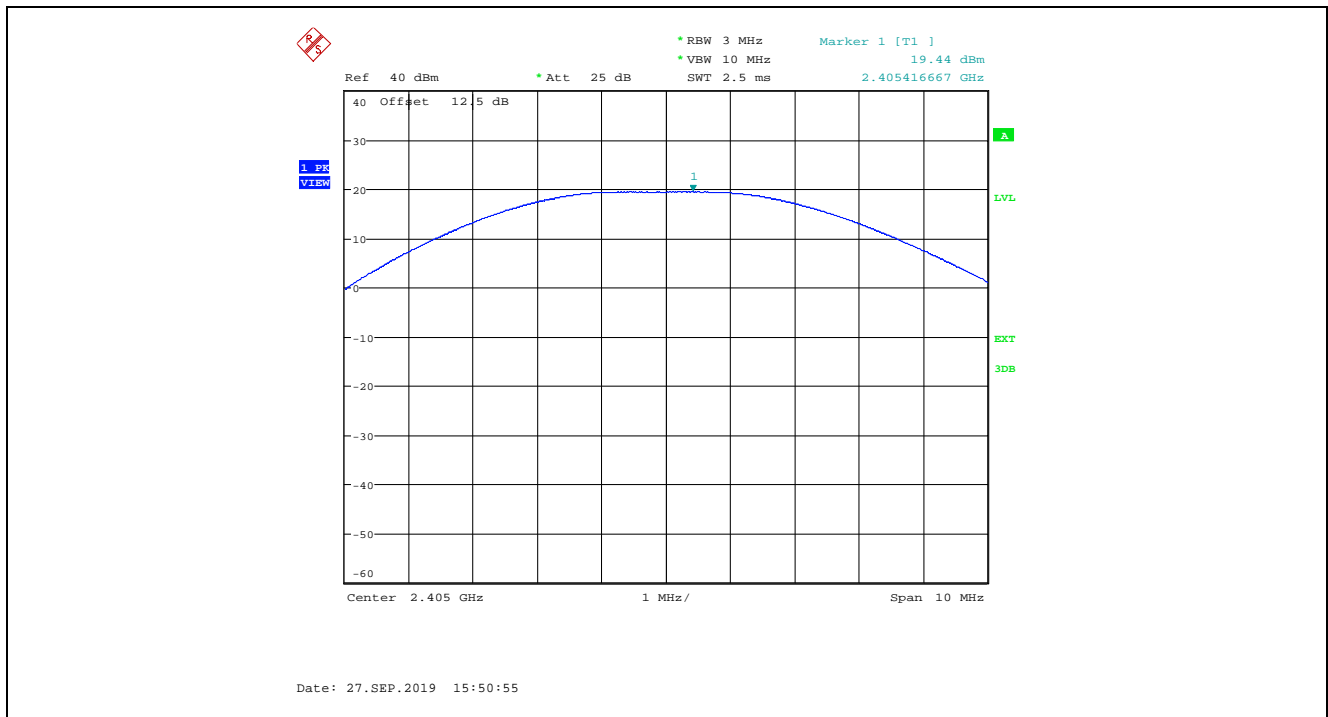

Plot 5.1.4.2. Maximum Peak Conducted Output Power, QPSK Modulation, Power Setting 20, Ch 18, 2440 MHz

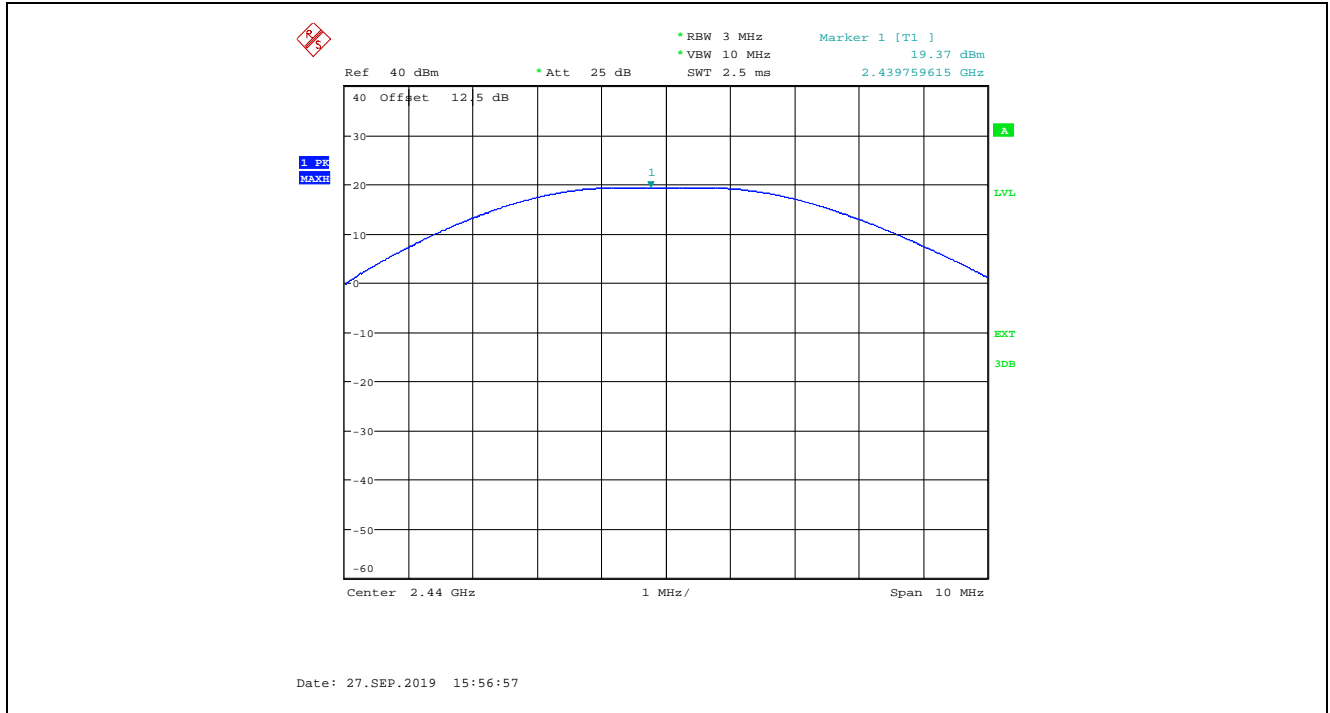

Plot 5.1.4.3. Maximum Peak Conducted Output Power, QPSK Modulation, Power Setting 20, Ch 25, 2475 MHz

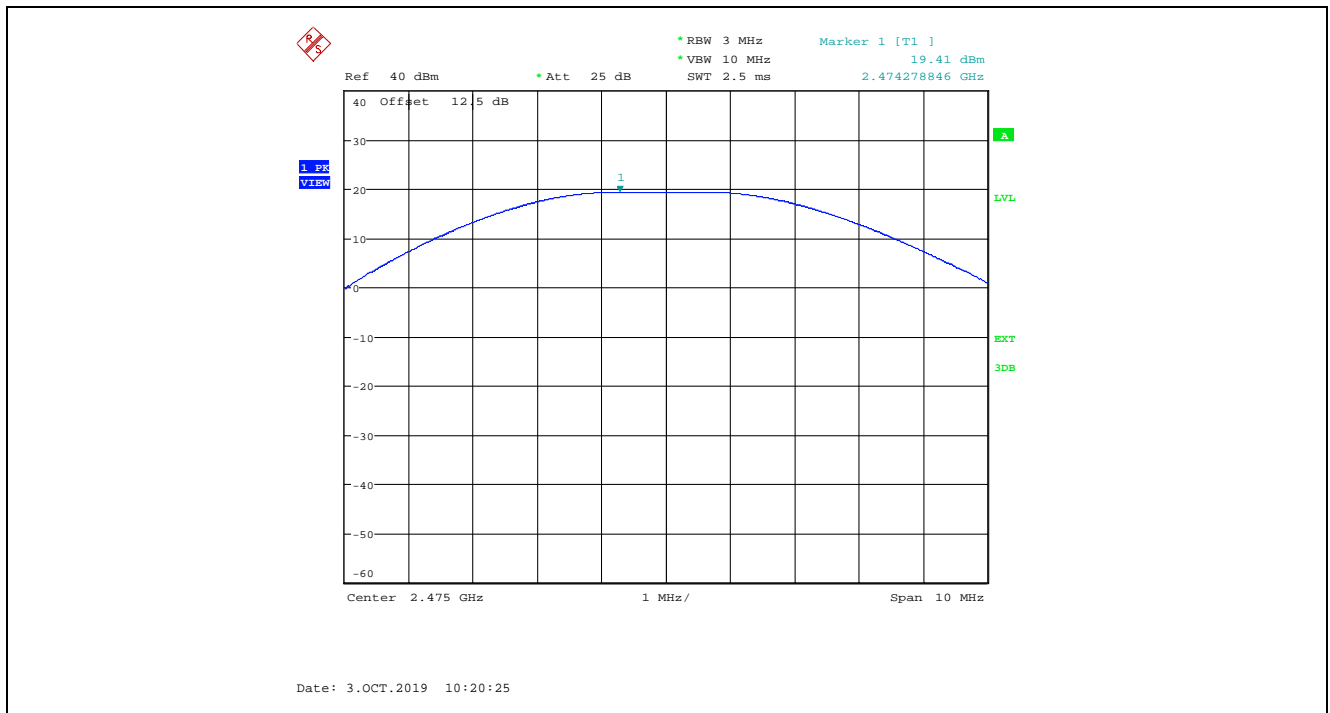

Plot 5.1.4.4. Maximum Peak Conducted Output Power, QPSK Modulation, Power Setting 16, Ch 26, 2480 MHz

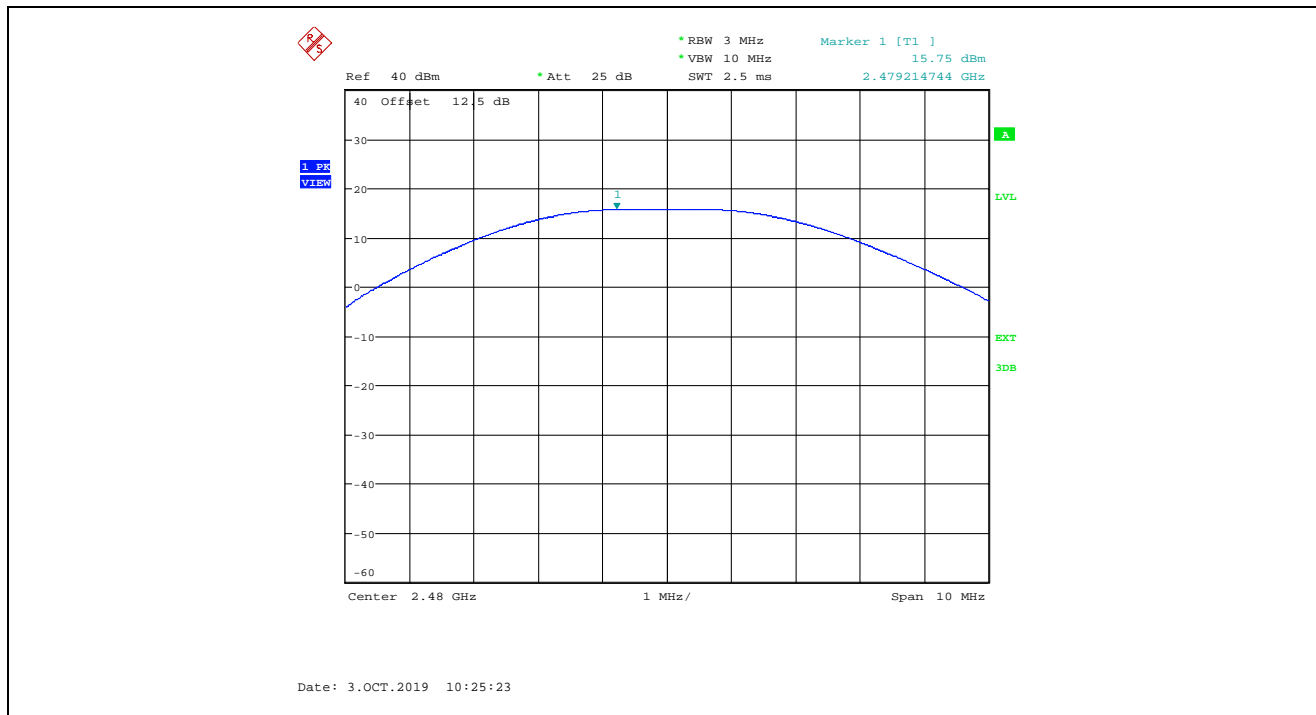

5.2. UNWANTED EMISSIONS (RADIATED) [RSS-247, SECTION 5.5]

5.2.1. Limit(s)

In any 100 kHz bandwidth outside the frequency band in which the spread spectrum or digitally modulated device is operating, the RF power that is produced shall be at least 20 dB below that in the 100 kHz bandwidth within the band that contains the highest level of the desired power, based on either an RF conducted or a radiated measurement, provided that the transmitter demonstrates compliance with the peak conducted power limits. If the transmitter complies with the conducted power limits based on the use of root-mean-square averaging over a time interval, as permitted under section 5.4(d), the attenuation required shall be 30 dB instead of 20 dB. Attenuation below the general field strength limits specified in RSS-Gen is not required.

RSS-Gen, Section 8.10 Restricted Frequency Bands

Restricted frequency bands, identified in table 7, are designated primarily for safety-of-life services (distress calling and certain aeronautical activities), certain satellite downlinks, radio astronomy and some government uses. Except where otherwise indicated, the following conditions related to the restricted frequency bands apply:

- (a) The transmit frequency, including fundamental components of modulation, of licence-exempt radio apparatus shall not fall within the restricted frequency bands listed in table 7 except for apparatus compliant with RSS-287, *Emergency Position Indicating Radio Beacons (EPIRB)*, *Emergency Locator Transmitters (ELT)*, *Personal Locator Beacons (PLB)*, and *Maritime Survivor Locator Devices (MSLD)*.
- (b) Unwanted emissions that fall into restricted frequency bands listed in table 7 shall comply with the limits specified in table 5 and table 6.
- (c) Unwanted emissions that do not fall within the restricted frequency bands listed in table 7 shall comply either with the limits specified in the applicable RSS or with those specified in table 5 and table 6.

RSS-Gen Table 5 - General Field Strength Limits at Frequencies Above 30 MHz

Frequency (MHz)	Field Strength (microvolts/m at 3 metres)
30 - 88	100
88 - 216	150
216 - 960	200
Above 960*	500

Table 6 – General Field Strength Limits at Frequencies Below 30 MHz

Frequency	Magnetic field strength (H-Field) (µA/m)	Measurement distance (m)
9 - 490 kHz ¹	6.37/F (F in kHz)	300
490 - 1705 kHz	63.7/F (F in kHz)	30
1.705 - 30 MHz	0.08	30
Note 1: The emission limits for the ranges 9-90 kHz and 110-490 kHz are based on measurements employing a linear average detector.		

RSS-Gen Table 7 – Restricted Frequency Bands*

MHz	MHz	GHz
0.090-0.110	240-285	9.0-9.2
2.1735-2.1905	322-335.4	9.3-9.5
3.020-3.026	399.9-410	10.6-12.7
4.125-4.128	608-614	13.25-13.4
4.17725-4.17775	960-1427	14.47-14.5
4.20725-4.20775	1435-1626.5	15.35-16.2
5.677-5.683	1645.5-1646.5	17.7-21.4
6.215-6.218	1660-1710	22.01-23.12
6.26775-6.26825	1718.8-1722.2	23.6-24.0
6.31175-6.31225	2200-2300	31.2-31.8
8.291-8.294	2310-2390	36.43-36.5
8.362-8.366	2655-2900	Above 38.6
8.37625-8.38675	3260-3267	
8.41425-8.41475	3332-3339	
12.29-12.293	3345.8-3358	
12.51975-12.52025	3500-4400	
12.57675-12.57725	4500-5150	
13.36-13.41	5350-5460	
16.42-16.423	7250-7750	
16.69475-16.69525	8025-8500	
16.80425-16.80475		
25.5-25.67		
37.5-38.25		
73-74.6		
74.8-75.2		
108-138		
156.52475-156.52525		
156.7-156.9		

* Certain frequency bands listed in table 7 and in bands above 38.6 GHz are designated for licence-exempt applications. These frequency bands and the requirements that apply to related devices are set out in the 200 and 300 series of RSSs.

5.2.2. Method of Measurements

KDB 558074 D01 15.247 Meas Guidance v05r02, Sections 8.5, 8.6 and 8.7 (ANSI C63.10-2013 Clauses 11.11, 11.12 and 11.13)

5.2.3. Test Arrangement

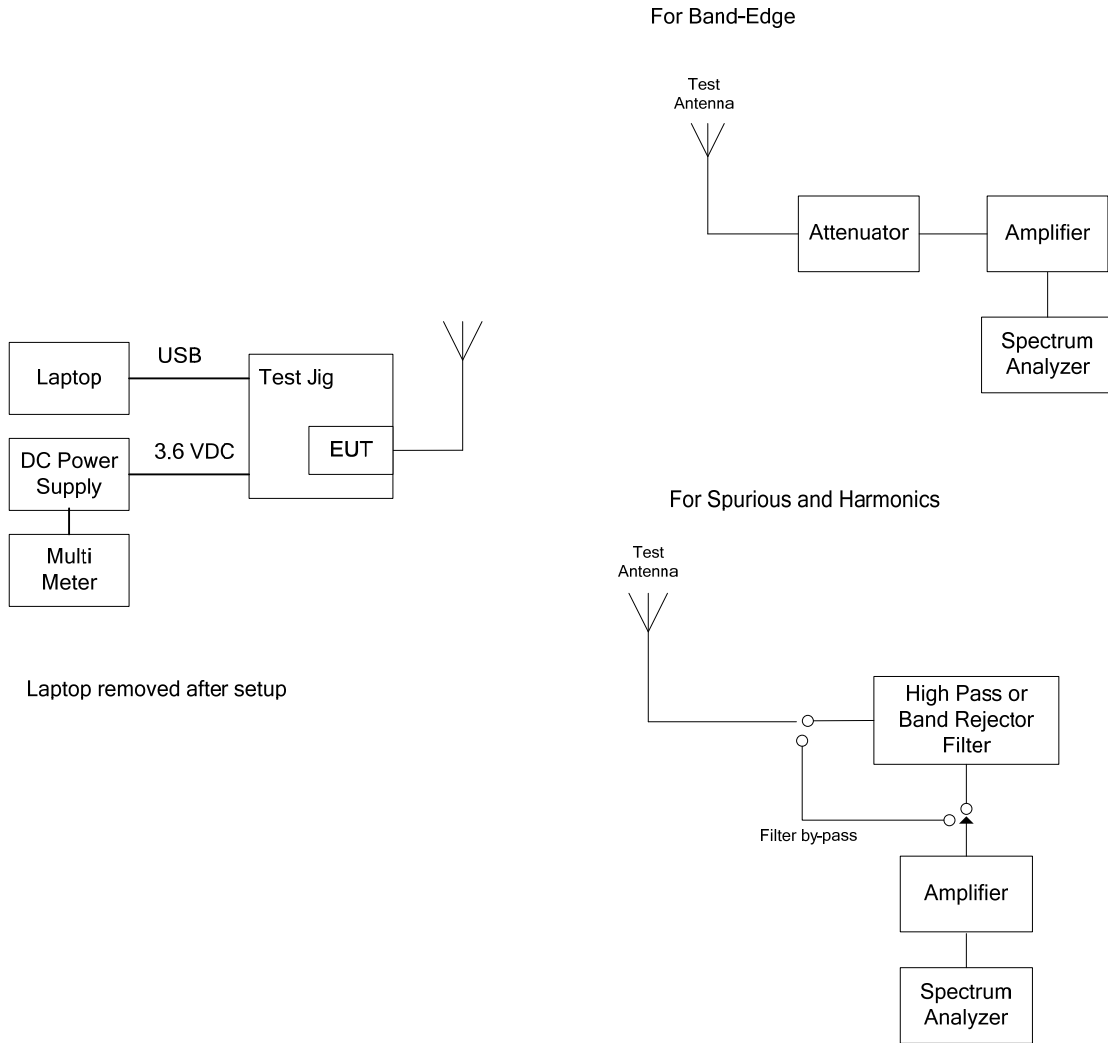

5.2.4. Test Data

Remark(s):

- All spurious emissions that are in excess of 20 dB below the specified limit shall be recorded.
- EUT shall be tested in three orthogonal positions.
- The following test data represent the worst-case derived from exploratory tests.

5.2.4.1. Spurious Radiated Emission

Fundamental Frequency:		2405 MHz					
Power Setting:		20					
Frequency Test Range:		30 MHz – 25 GHz					
Frequency (MHz)	RF Peak Level (dB μ V/m)	RF Avg Level (dB μ V/m)	Antenna Plane (H/V)	Limit RSS-Gen Table 5 (dB μ V/m)	Limit RSS-247 Section 5.5 (dB μ V/m)	Margin (dB)	Pass/Fail
2405	110.95	--	V	--	--	--	--
2405	110.80	--	H	--	--	--	--
4810	56.59	46.40	V	54.0	91.0	-7.6	Pass*
4810	56.20	45.70	H	54.0	91.0	-8.3	Pass*
All other spurious emissions and harmonics are more than 20 dB below the applicable limit.							

Fundamental Frequency:		2440 MHz					
Power Setting:		20					
Frequency Test Range:		30 MHz – 25 GHz					
Frequency (MHz)	RF Peak Level (dB μ V/m)	RF Avg Level (dB μ V/m)	Antenna Plane (H/V)	Limit RSS-Gen Table 5 (dB μ V/m)	Limit RSS-247 Section 5.5 (dB μ V/m)	Margin (dB)	Pass/Fail
2440	111.89	--	V	--	--	--	--
2440	113.35	--	H	--	--	--	--
4880	52.47	41.30	V	54.0	93.4	-12.7	Pass*
4880	53.37	42.66	H	54.0	93.4	-11.3	Pass*
7320	51.19	37.89	V	54.0	93.4	-16.1	Pass*
7320	52.06	38.15	H	54.0	93.4	-15.9	Pass*
All other spurious emissions and harmonics are more than 20 dB below the applicable limit.							

Fundamental Frequency:		2475 MHz					
Power Setting:		20					
Frequency Test Range:		30 MHz – 25 GHz					
Frequency (MHz)	RF Peak Level (dBµV/m)	RF Avg Level (dBµV/m)	Antenna Plane (H/V)	Limit RSS-Gen Table 5 (dBµV/m)	Limit RSS-247 Section 5.5 (dBµV/m)	Margin (dB)	Pass/Fail
2475	111.39	--	V	--	--	--	--
2475	114.56	--	H	--	--	--	--
4950	51.63	39.55	V	54.0	94.6	-14.5	Pass*
4950	52.38	40.42	H	54.0	94.6	-13.6	Pass*
7425	50.78	36.97	V	54.0	94.6	-17.0	Pass*
7425	51.73	37.36	H	54.0	94.6	-16.6	Pass*
All other spurious emissions and harmonics are more than 20 dB below the applicable limit.							

Fundamental Frequency:		2480 MHz					
Power Setting:		16					
Frequency Test Range:		30 MHz – 25 GHz					
Frequency (MHz)	RF Peak Level (dBµV/m)	RF Avg Level (dBµV/m)	Antenna Plane (H/V)	Limit RSS-Gen Table 5 (dBµV/m)	Limit RSS-247 Section 5.5 (dBµV/m)	Margin (dB)	Pass/Fail
2480	109.63	--	V	--	--	--	--
2480	110.41	--	H	--	--	--	--
4960	50.84	39.65	V	54.0	90.4	-14.4	Pass*
4960	52.89	41.85	H	54.0	90.4	-12.2	Pass*
7440	51.44	37.05	V	54.0	90.4	-17.0	Pass*
7440	51.91	37.17	H	54.0	90.4	-16.8	Pass*
All other spurious emissions and harmonics are more than 20 dB below the applicable limit.							

5.2.4.2. Band-Edge Radiated Emissions

Plot 5.2.4.2.1. Band-Edge Radiated Emissions, Lower Band-edge, Peak Detector
Rx Antenna in Vertical Polarization, QPSK Modulation, Power Setting 20, Ch 11, 2405 MHz

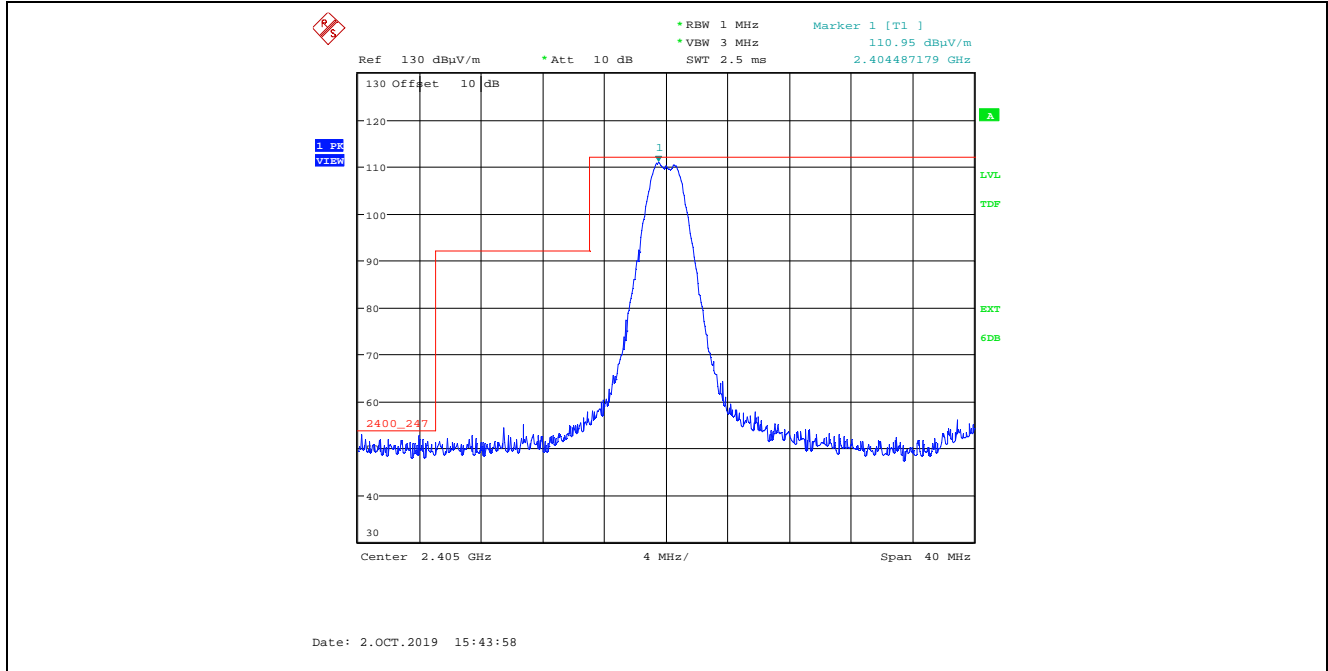

Plot 5.2.4.2.2. Band-Edge Radiated Emissions, Lower Band-edge, Peak Detector
Rx Antenna in Horizontal Polarization, QPSK Modulation, Power Setting 20, Ch 20, 2405 MHz

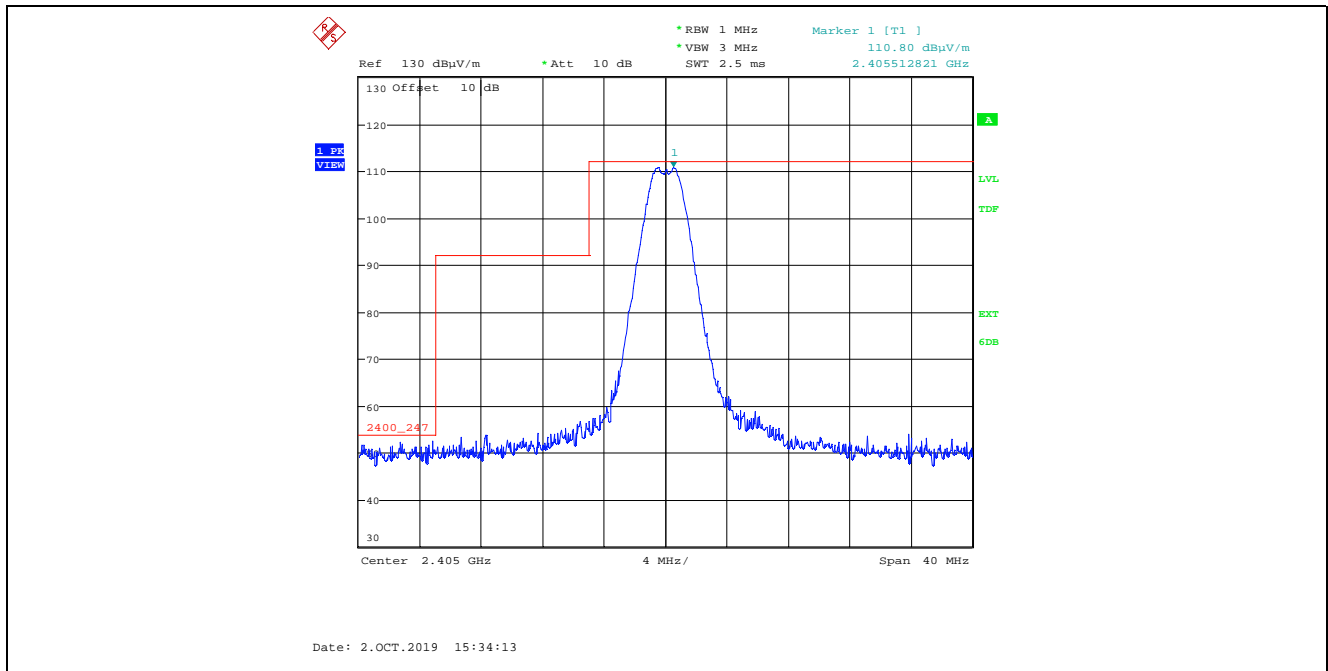

Plot 5.2.4.2.3. Band-Edge Radiated Emissions, Higher Band-edge, Peak Detector
Rx Antenna in Vertical Polarization, QPSK Modulation, Power Setting 20, Ch 25, 2475 MHz

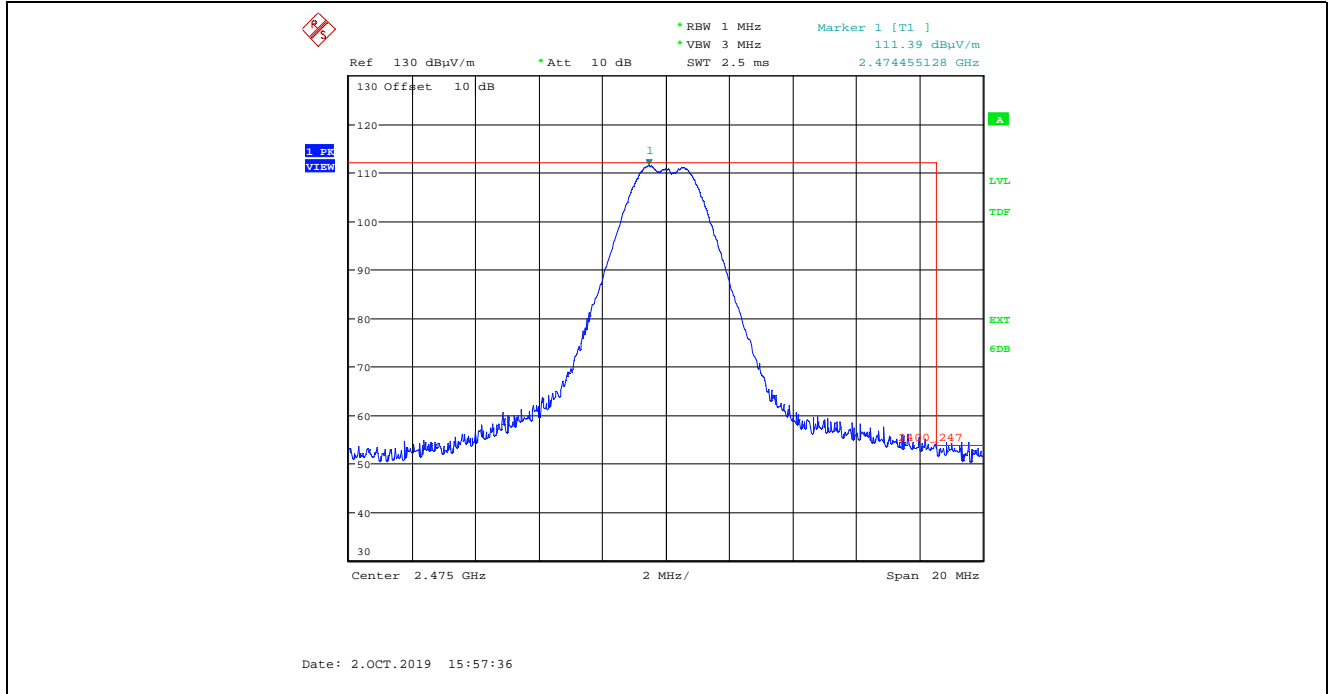

Plot 5.2.4.2.4. Band-Edge Radiated Emissions, Higher Band-edge, Average Detector
Rx Antenna in Vertical Polarization, QPSK Modulation, Power Setting 20, Ch 25, 2475 MHz

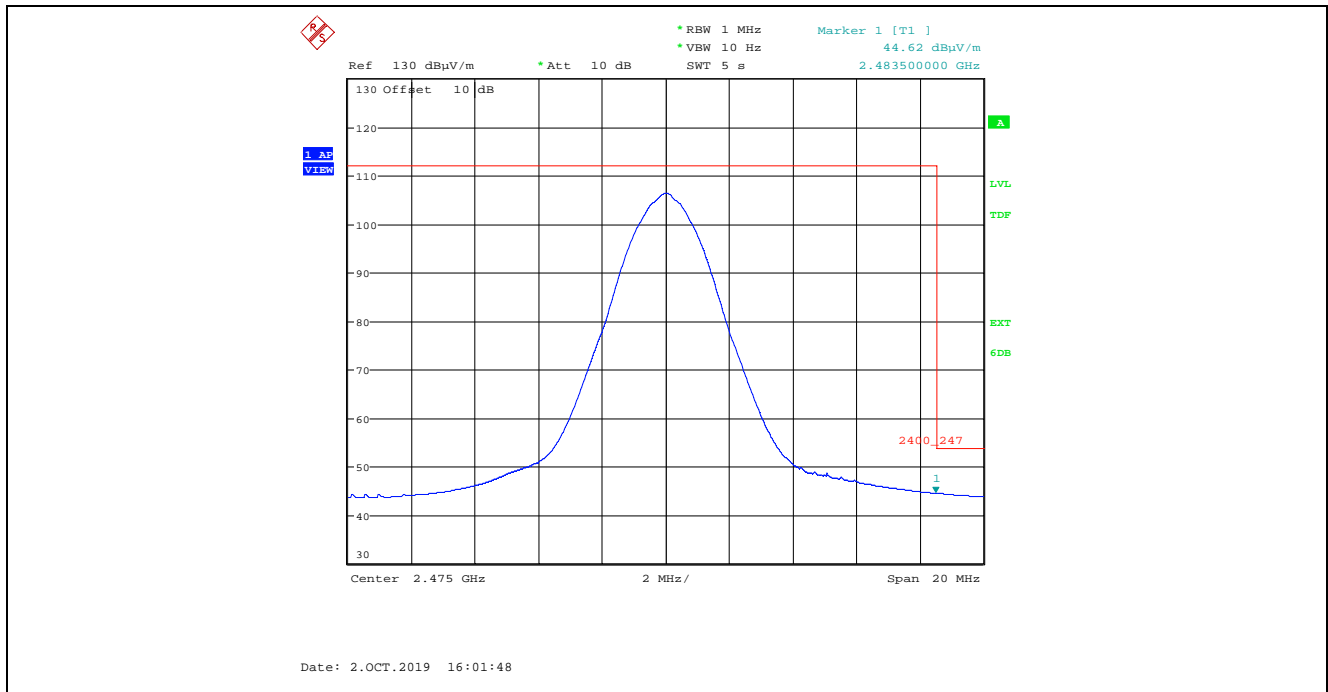

Plot 5.2.4.2.5. Band-Edge Radiated Emissions, Higher Band-edge, Peak Detector
 Rx Antenna in Horizontal Polarization, QPSK Modulation, Power Setting 20, Ch 25, 2475 MHz

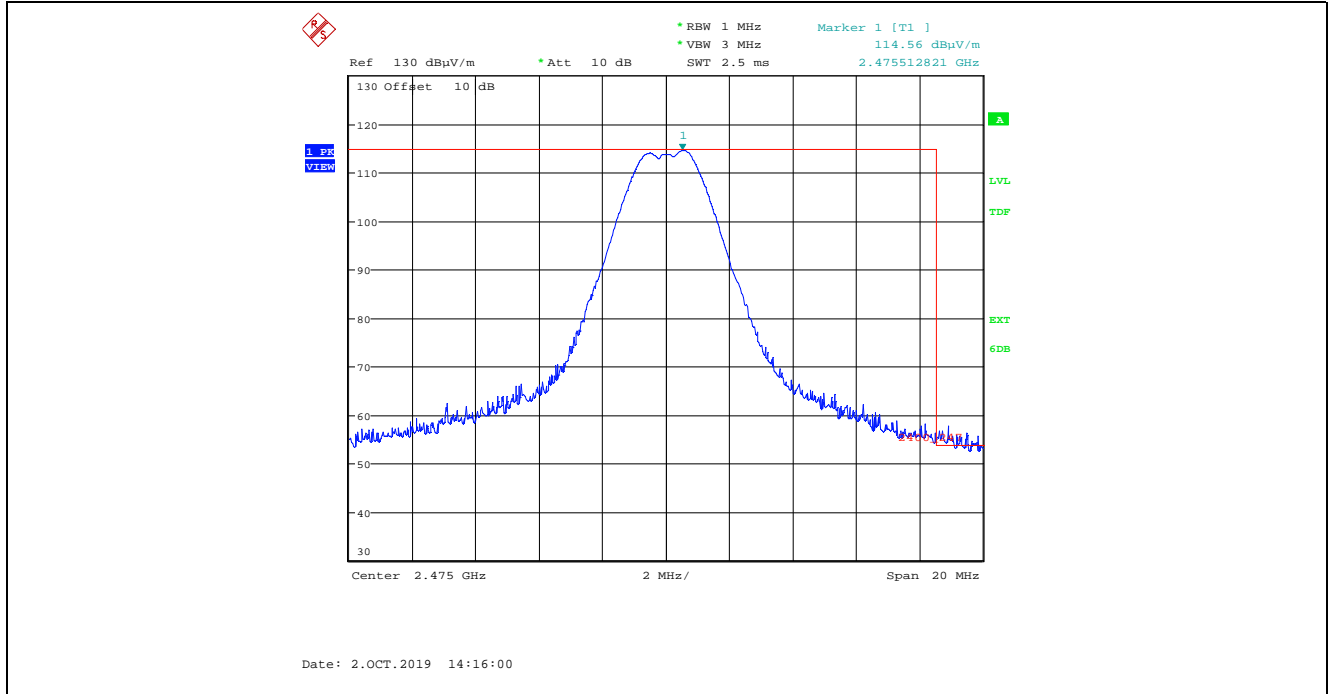

Plot 5.2.4.2.6. Band-Edge Radiated Emissions, Higher Band-edge, Average Detector
 Rx Antenna in Horizontal Polarization, QPSK Modulation, Power Setting 20, Ch 25, 2475 MHz

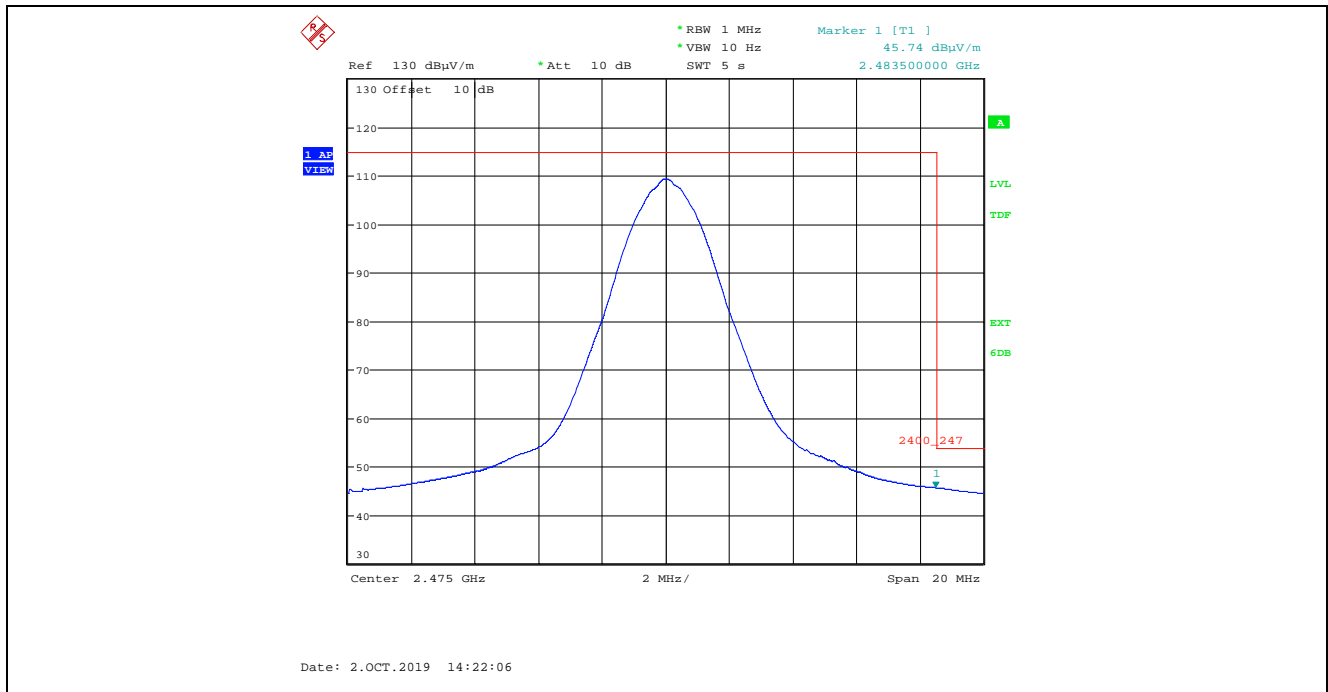

Plot 5.2.4.2.7. Band-Edge Radiated Emissions, Higher Band-edge, Peak Detector
Rx Antenna in Vertical Polarization, QPSK Modulation, Power Setting 16, Ch 26, 2480 MHz

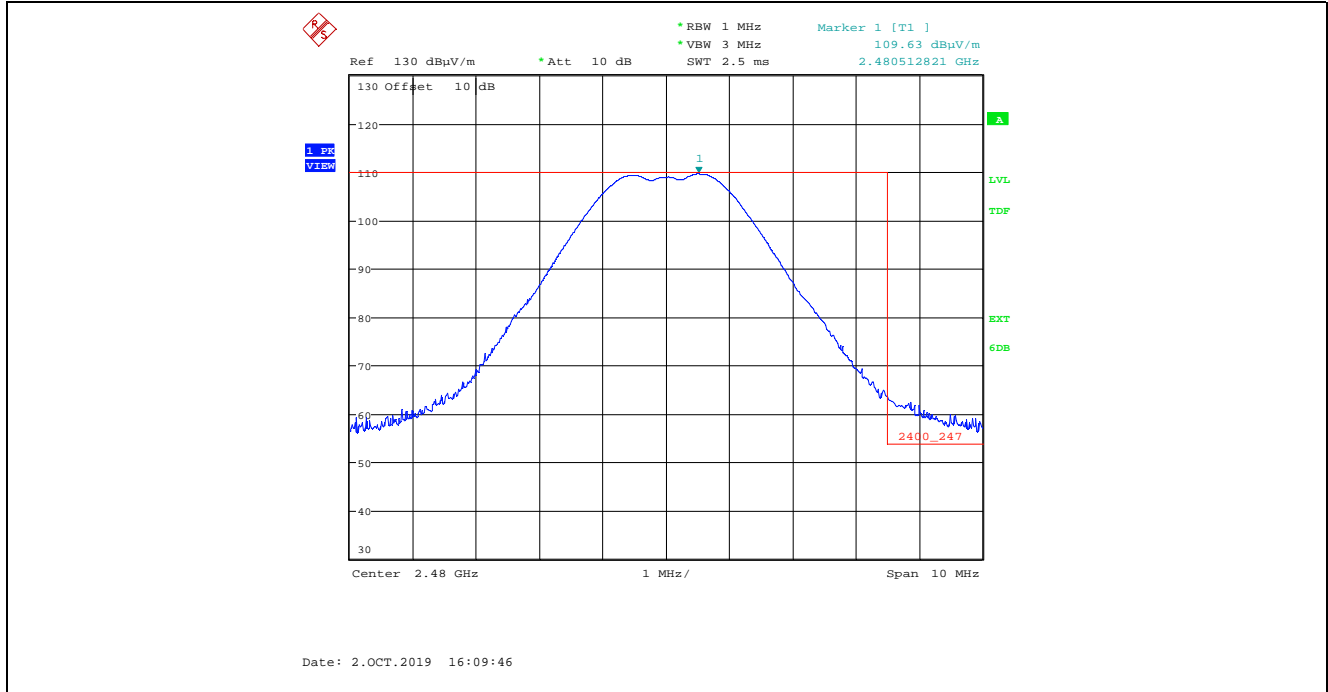

Plot 5.2.4.2.8. Band-Edge Radiated Emissions, Higher Band-edge, Average Detector
Rx Antenna in Vertical Polarization, QPSK Modulation, Power Setting 16, Ch 26, 2480 MHz

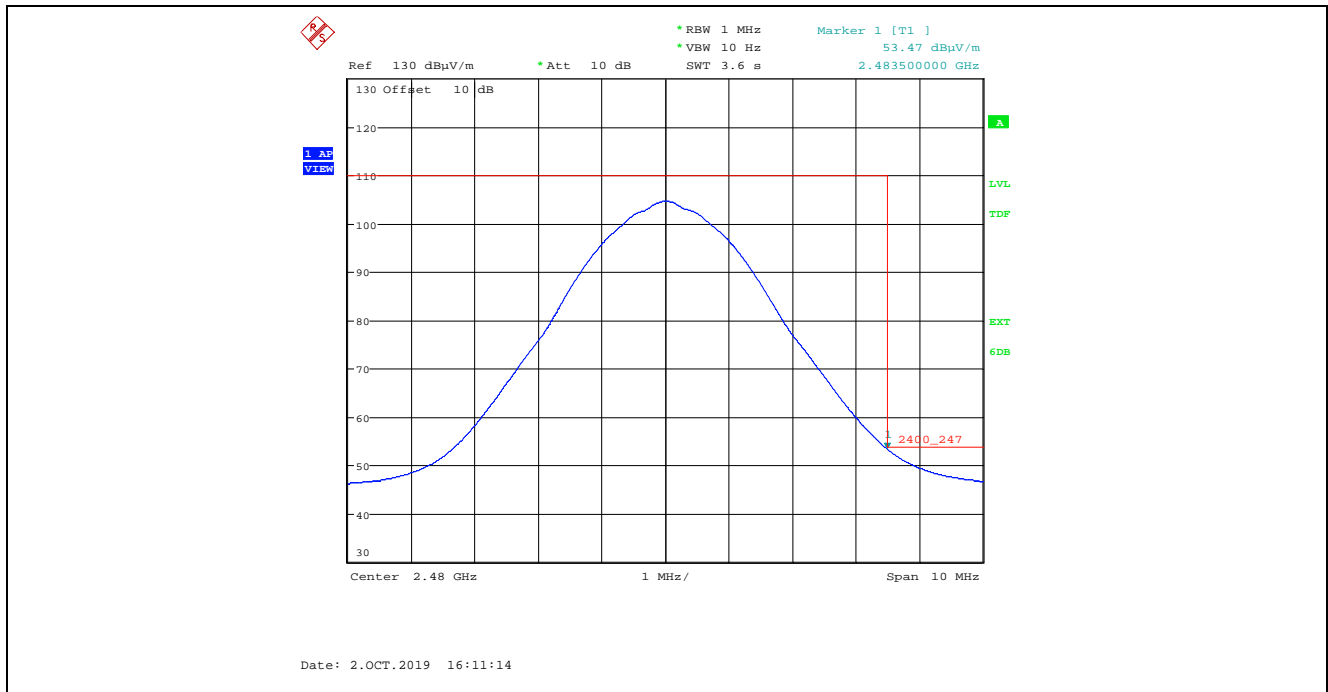

Plot 5.2.4.2.9. Band-Edge Radiated Emissions, Higher Band-edge, Peak Detector
 Rx Antenna in Horizontal Polarization, QPSK Modulation, Power Setting 16, Ch 26, 2480 MHz

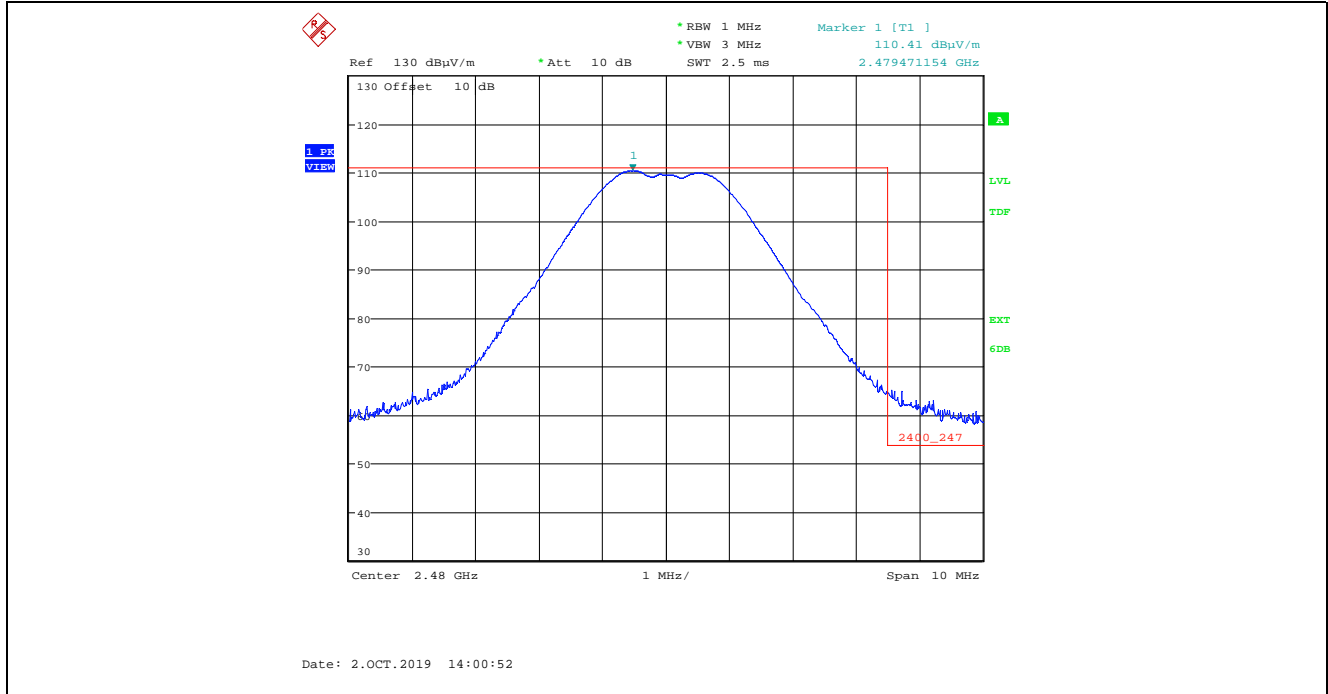

Plot 5.2.4.2.10. Band-Edge Radiated Emissions, Higher Band-edge, Average Detector
 Rx Antenna in Horizontal Polarization, QPSK Modulation, Power Setting 16, Ch 26, 2480 MHz

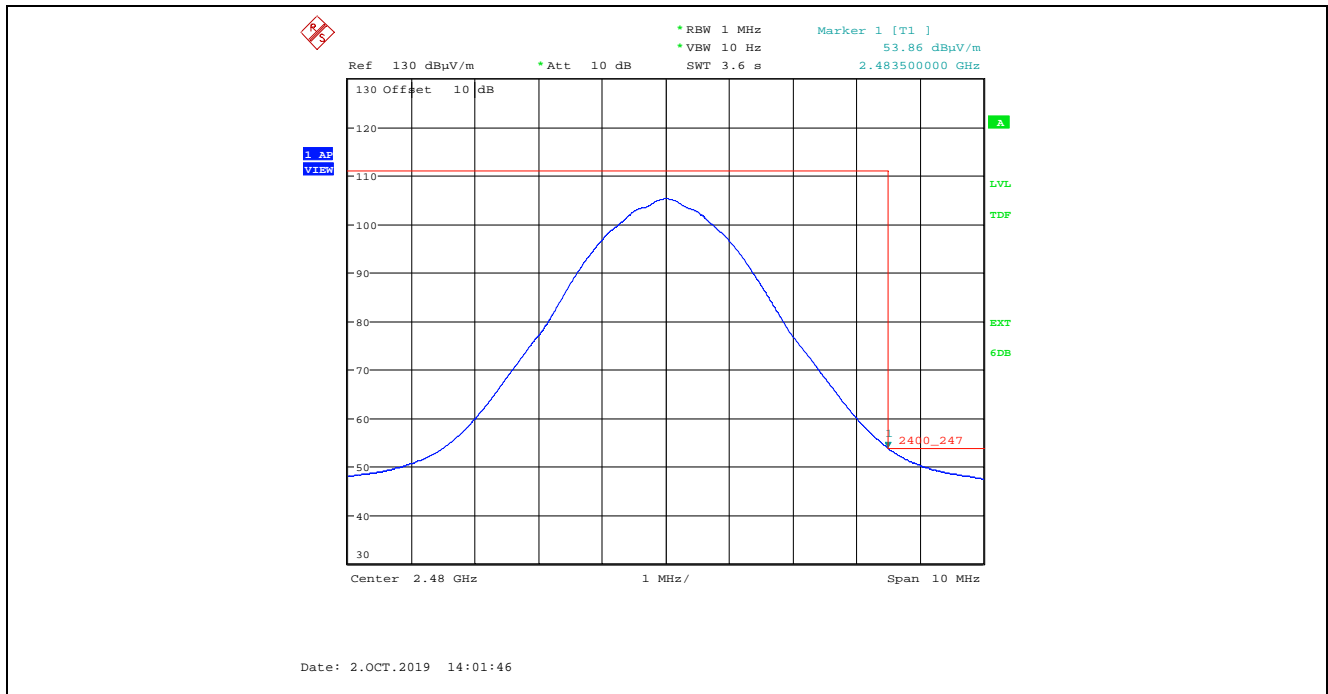

5.3. EXPOSURE OF HUMANS TO RF FIELD [RSS-Gen, SECTION 3.4 & RSS-102]

The criteria listed in the following table shall be used to evaluate the environmental impact of human exposure to radio-frequency (RF) radiation as specified in RSS-102

Table 4: RF Field Strength Limits for Devices Used by the General Public (Uncontrolled Environment)

Frequency Range (MHz)	Electric Field (V/m rms)	Magnetic Field (A/m rms)	Power Density (W/m ²)	Reference Period (minutes)
0.003-10 ²¹	83	90	-	Instantaneous*
0.1-10	-	0.73/ <i>f</i>	-	6**
1.1-10	87/ <i>f</i> ^{0.5}	-	-	6**
10-20	27.46	0.0728	2	6
20-48	58.07/ <i>f</i> ^{0.25}	0.1540/ <i>f</i> ^{0.25}	8.944/ <i>f</i> ^{0.5}	6
48-300	22.06	0.05852	1.291	6
300-6000	3.142 <i>f</i> ^{0.3417}	0.008335 <i>f</i> ^{0.3417}	0.02619 <i>f</i> ^{0.6834}	6
6000-15000	61.4	0.163	10	6
15000-150000	61.4	0.163	10	616000/ <i>f</i> ^{1.2}
150000-300000	0.158 <i>f</i> ^{0.5}	4.21 x 10 ⁻⁴ <i>f</i> ^{0.5}	6.67 x 10 ⁻⁵ <i>f</i>	616000/ <i>f</i> ^{1.2}

Note: *f* is frequency in MHz.
 *Based on nerve stimulation (NS).
 ** Based on specific absorption rate (SAR).

5.3.1. Method of Measurements

Calculation Method of Power Density/RF Safety Distance:

$$S = \frac{PG}{4\pi \cdot r^2} = \frac{EIRP}{4\pi \cdot r^2}$$

Where,
 P: power input to the antenna in mW
 EIRP: Equivalent (effective) isotropic radiated power.
 S: power density mW/cm²
 G: numeric gain of antenna relative to isotropic radiator
 r: distance to centre of radiation in cm

5.3.2. RF Evaluation

Frequency (MHz)	EIRP (dBm)	EIRP (W)	Evaluation Distance, r (m)	Power Density, S (W/m ²)	MPE Limit (W/m ²)	Margin (W/m ²)
2405	23.44	0.221	0.2	0.440	5.355	-4.915

EXHIBIT 6. TEST EQUIPMENT LIST

Test Instruments	Manufacturer	Model No.	Serial No.	Frequency Range	Cal. Due Date
Spectrum Analyzer	Rohde & Schwarz	FSU26	200946	20Hz–26.5 GHz	Jul 25, 2020
Attenuator	Hewlett Packard	8493C	0465	DC–26.5 GHz	See Note 1
DC Block	Hewlett Packard	11742A	12460	0.045 – 26.5 GHz	See Note 1
DC Power Supply	HQ Power	PS613U	NSN	0-30VDC	See Note 1
Multi-meter	Fluke	8842A	5021295	20mV - 1kV	Oct 23, 2019
EMI Receiver	Rohde & Schwarz	ESU40	100037	20Hz–40 GHz	Mar 15, 2020
RF Amplifier	Com-Power	PAM-0118A	551052	0.5 – 18 GHz	Jul 26, 2019
RF Amplifier	Hewlett Packard	84498	3008A00769	1 – 26.5 GHz	May 15, 2020
Biconilog Antenna	EMCO	3142B	1575	26-2000 MHz	May 10, 2020
Horn Antenna	EMCO	3155	6570	1 – 18 GHz	Oct 11, 2020
Horn Antenna	ETS-Lindgren	3160-09	001183858	18 – 26.5 GHz	Oct 27, 2020
High Pass Filter	K & L	11SH10-4000/T12000	4	Cut off 2.4 GHz	See Note 1
Band Reject Filter	Micro-Tronics	BRM50701	105	Cut off 2.4-2.483 GHz	See Note 1
Note 1: Internal Verification/Calibration check					

EXHIBIT 7. MEASUREMENT UNCERTAINTY

The measurement uncertainties stated were calculated in accordance with the requirements of CISPR 16-4-2 @ IEC:2003 and JCGM 100:2008 (GUM 1995) – Guide to the Expression of Uncertainty in Measurement.

7.1. RADIATED EMISSION MEASUREMENT UNCERTAINTY

	Radiated Emission Measurement Uncertainty @ 3m, Horizontal (30-1000 MHz):	Measured (dB)	Limit (dB)
u_c	Combined standard uncertainty: $u_c(y) = \sqrt{\sum_{i=1}^m u_i^2(y)}$	± 2.39	± 2.6
U	Expanded uncertainty U: $U = 2u_c(y)$	± 4.79	± 5.2

	Radiated Emission Measurement Uncertainty @ 3m, Vertical (30-1000 MHz):	Measured (dB)	Limit (dB)
u_c	Combined standard uncertainty: $u_c(y) = \sqrt{\sum_{i=1}^m u_i^2(y)}$	± 2.39	± 2.6
U	Expanded uncertainty U: $U = 2u_c(y)$	± 4.78	± 5.2

	Radiated Emission Measurement Uncertainty @ 3 m, Horizontal & Vertical (1 – 18 GHz):	Measured (dB)	Limit (dB)
u_c	Combined standard uncertainty: $u_c(y) = \sqrt{\sum_{i=1}^m u_i^2(y)}$	± 1.87	Under consideration
U	Expanded uncertainty U: $U = 2u_c(y)$	± 3.75	Under consideration