

# Migration from 9XStream-PKG Modem to XBee-PRO XSC RF Modem

This guide will assist you with migrating from the 9XStream-PKG Modem to the XBee-PRO XSC RF Modem.

Even though the function of these radios is basically the same; this guide lists some of the basic hardware and software differences between the radios and what you need to consider when migrating from the 9XStream-PKG Modem to the XBee-PRO XSC RF Modem.

9XStream-PKG RS-232/422/485



XBee-PRO XSC RF Modem RS-422/485 Variant



## Hardware Considerations

The following chart lists the major hardware differences between the 9XStream-PKG Modem and the XBee-PRO XSC RF Modem.

The 9XStream-PKG Modem was a single unit that could handle RS-232, 422 and 485. It was also available in a USB variant.

The XBee-PRO XSC RF Modem comes in one of three variants: RS-232, RS-422/485 or USB. A single unit no longer handles RS-232, 422 and 485 so the correct variant needs to be ordered.

Considerations	9XStream-PKG	XBee-PRO XSC RF Modem	Comments
<b>Supply Voltage</b>	7-18 VCD	7-30 VDC	Power connector is center positive barrel jack.
<b>Interface</b>	-DB9 Female (RS-232/422/485) -USB	-DB9 Female (RS-232) -Phoenix Connector (RS- 422/485) -USB -Mini USB Connector (RS-232, RS-485)	-9XStream-PKG capable of RS-232/422/485 using DIP switches -XSC RF Modem comes in separate RS-232 and RS-422/485 versions - XSC RF Modem uses a mini USB connector as an added option for configuration on both RS-232 and RS-485 variants. RS-232/485 ports can also be used for configuration
<b>TX Current Draw</b>	170 mA (@9V)	140 mA (@9V)	Improved
<b>RX Current Draw</b>	70 mA	60 mA (@9V)	Improved
<b>Power Output</b>	20 dBm	24 dBm	Power output has increased, but is also software adjustable.
<b>FCC ID</b>	OUR-9XSTREAM	MCQ-XB900HP	Shown on label.
<b>IC ID</b>	4214A-9XSTREAM	1846A-XB900HP	Shown on label.
<b>Dimensions</b>	2.750" x 5.500" x 1.125" (6.99cm x 13.97" x 2.86cm)	4.500" x 2.750" x 1.125" (11.4cm x 7.0cm x 2.9cm)	XSC is slightly shorter in length (-1")
<b>Enclosure</b>	7.1 oz. (200g), Extruded aluminum, black anodized	5.25 oz. (150g), Extruded aluminum, black anodized	Includes mounting holes.
<b>RF Connectors</b>	RPSMA	RPSMA	RP-SMA Female Connector
<b>Operating Temperature</b>	-40 to 85° C	-40 to 85° C	Industrial rated
<b>MSRP</b>	\$244/*\$265	\$125/*\$145	*Includes Accessories

# Software Considerations

The following chart lists the major software differences between the 9XStream-PKG Modem and the XBee-PRO XSC RF Modem.

Considerations	9XStream-PKG	XBee-PRO XSC Modem	Comments
Wake Time	40 ms	40 ms	Time from pin sleep to when CTS asserts and is ready to transmit data.
Software/AT Commands	Same	Some added	Added commands like power level should be considered. New commands are not required to be used for the interoperability of the radio.
Line Passing	Supported using flow control lines	Not supported	Line passing is not supported on the XSC.
RS-485 Modes	Supported	Supported	The XSC RF Modem comes in RS-232 and RS-485 versions. They are separate.
RF Data Rates	1.2 kbps, 9.6 kbps, and 19.2 kbps	9.6 kbps and 19.2 kbps	RF data rates can be changed on XSC using different firmware function sets. *see screenshots below
Australia	Supported	Supported	920 MHz version is supported on both radios.

\*

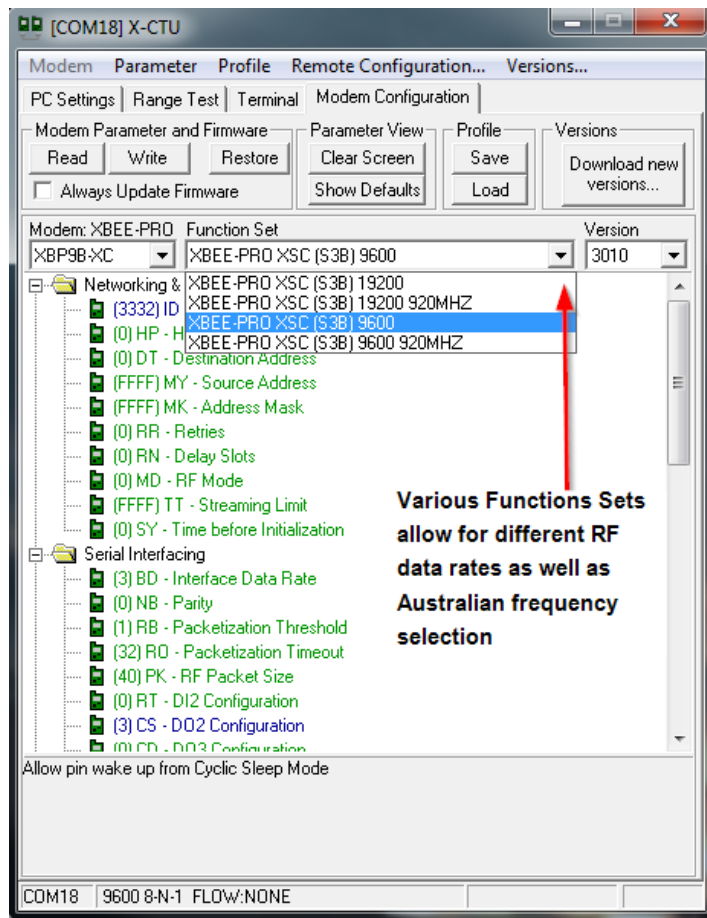

## Data Connectors

The XBee-PRO XSC RF Modem has three different variants. The first variant, the RS-232 version, uses a standard DB9 female connector as shown below:

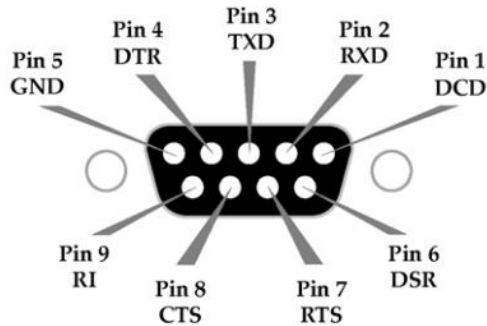

The second variant, the RS-422/485 version, uses a phoenix connector as shown below:

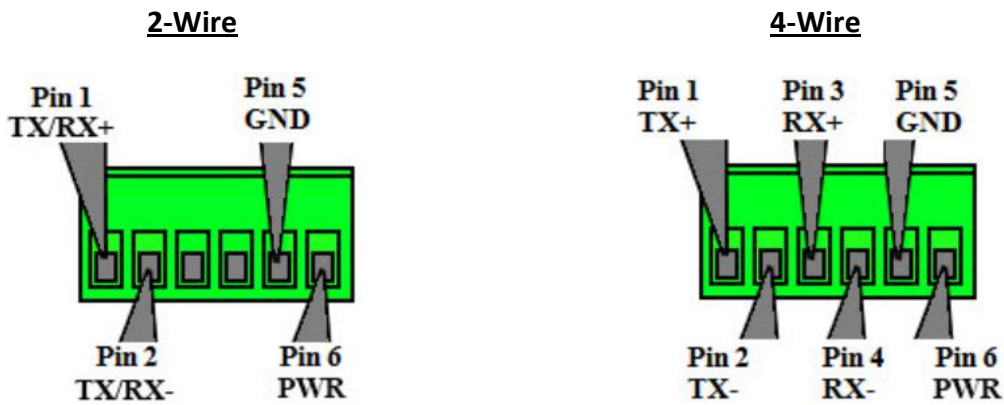

The third variant, the USB version, uses a Type B USB port as shown below:

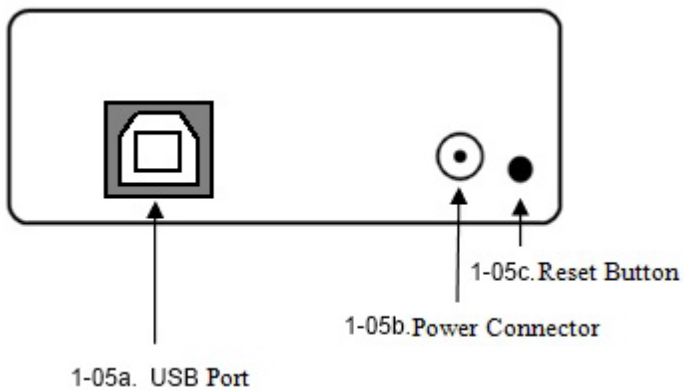

To facilitate ease of use, the RS-232 and RS-485 variants of the XBee-PRO XSC RF Modem include a mini-USB port for configuration of the radio as shown below:

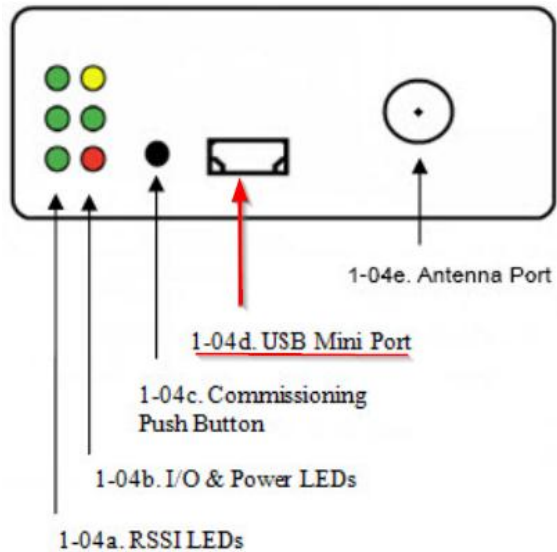

## Configuration

Both the 9XStream-PKG Modem and the XBee-PRO XSC RF Modem are configurable via AT Command Mode and Binary Command Mode. Some of the new commands on the XSC are not available through Binary Commands. Some of the new features on the XSC are MY (Source Address), MD (RF Mode), PK (RF Packet Size), PL (RF Power Level), RB (Packetization Threshold), and RZ (DI Buffer Size). All of these new features are described in more detail in the XBee-PRO XSC (S3B) product manual.

## Profile Migration

In order to integrate the new XBee-PRO XSC RF Modem into an existing network the common settings must be the same. To facilitate this, profile migration may occur. This process is described below:

1. Open X-CTU and select the proper COM port and COM port settings
2. Read from the old radio (9XStream-PKG)
3. Plug in the new radio (XBee-PRO XSC RF Modem)
4. Chose the XBP9B-XC modem type and appropriate function set
5. Click on Write
6. Click on Read to verify that the settings have taken