

STUFFING TABLE

OPTION DESCRIPTION	PART(S)	RCM3750 5 VOLT
SRAM	U2 JP2	512K 2-3
FLASH	U3 JP3	512K 2-3
BANK SELECT	JP1	1-2
INTERRUPT	R28	NOT INSTALLED
SERIAL FLASH	U9 AND C52 OR U13 AND C57	INSTALLED
BOARD REGULATOR	U7, C45, C47 OR U4, C45, C47	INSTALLED
	R10	NOT INSTALLED
BOARD POWER	R52	NOT INSTALLED
	R53, R54, R55, R56, R57, R58	INSTALLED
HEAT SINK	HS1	NOT INSTALLED
RTC	U8, C1	INSTALLED
	R7	NOT INSTALLED

REVISION HISTORY			REVISION APPROVAL			
REV	ECO	DESCRIPTION	PROJECT ENGINEER	APPROVAL DATE	DOCUMENT CONTROL	APPROVAL DATE
A	E13265	INITIAL RELEASE	TCP	4/12/05	KF	4/12/05
B	E14127	ADD SCHMITT TRIGGER (U8), R7 and C1 in RTC circuit	XT	10/17/05	KF	10/17/05

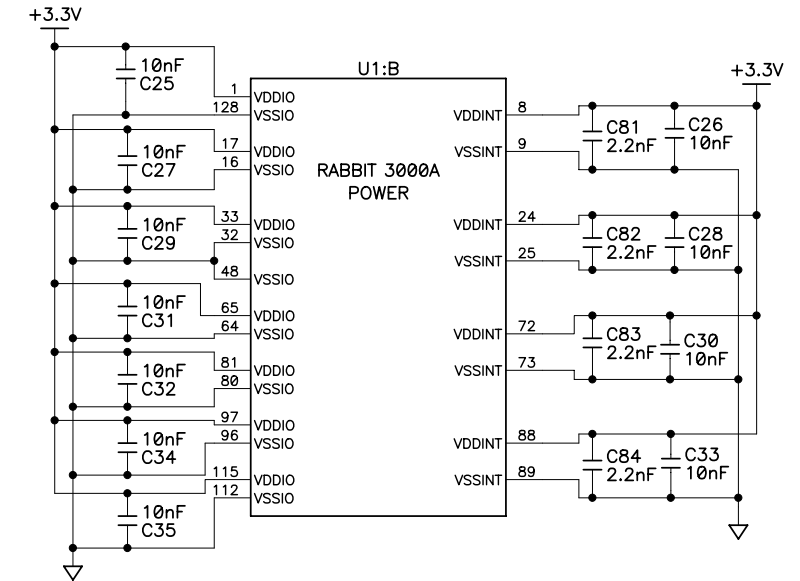

- NOTES: UNLESS OTHERWISE SPECIFIED;
- ALL RESISTOR VALUES ARE IN OHMS, 1/16W, 5%
  - ALL CAPACITORS ARE 10VDC OR HIGHER.
  - THE ORIGIN SOURCE OF A VOLTAGE IS REPRESENTED BY (VCC), AND ALL REFERENCES TO THAT VOLTAGE ARE REPRESENTED BY (VCC).
- 4 OUTLINED CIRCUIT MAY NOT BE STUFFED DEPENDING ON MODEL, SEE STUFFING CHART FOR CLARIFICATION.
5. COMPONENT VALUES SHOWN WITH AN ASTERISK (\*) FOLLOWING THE VALUE, MAY HAVE DIFFERENT VALUES, OR MAY NOT BE STUFFED DEPENDING ON MODEL.

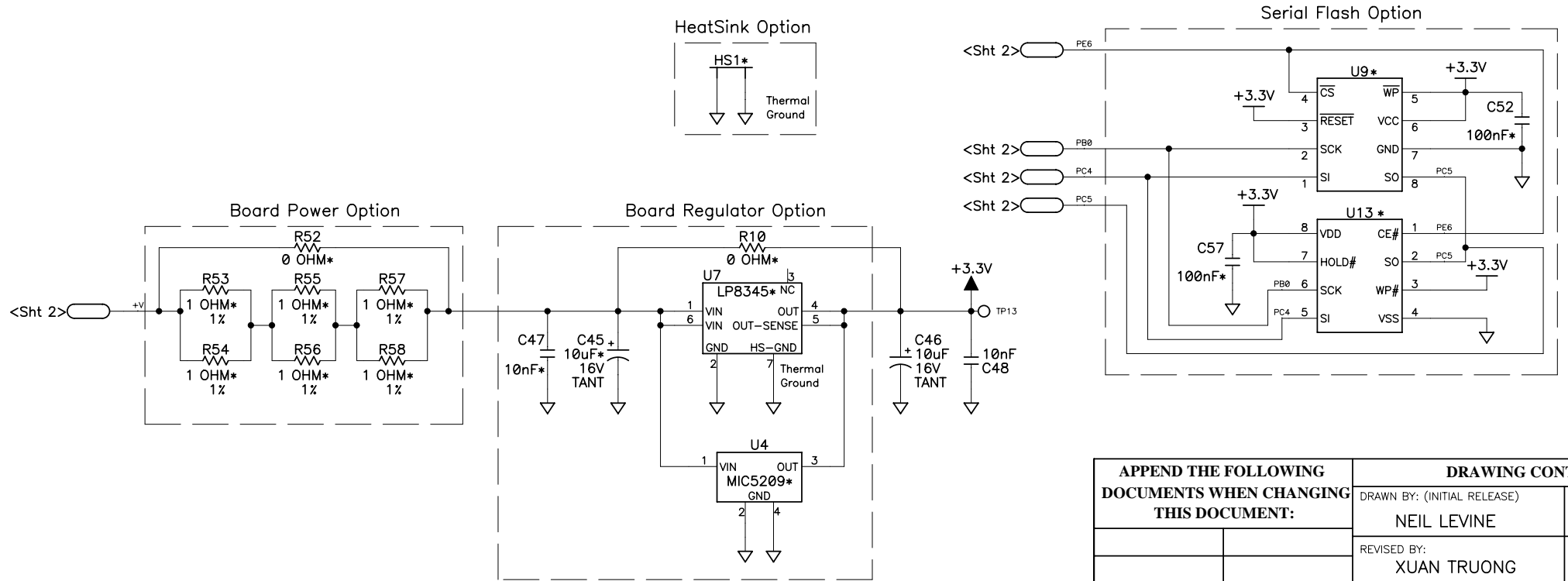

APPEND THE FOLLOWING DOCUMENTS WHEN CHANGING THIS DOCUMENT:		DRAWING CONTENT:		TITLE	
		DRAWN BY: (INITIAL RELEASE)		SCHEMATIC DIAGRAM	
		NEIL LEVINE	1/28/05	RCM3750	
		REVISOR BY:		Z-WORLD	
		XUAN TRUONG	10/03/05	2900 SPAFFORD ST. DAVIS, CA 95616 530 - 757 - 4616	
APPROVALS: INITIAL RELEASE				SIZE	DWG NO.
		PROJECT ENGINEER:		<b>B</b>	090-0210
		ENGINEERING MANAGER:		SCALE	NONE
				RELEASE DATE	
		SIGNATURES	DATE	SHEET	1 OF 3



# ETHERNET

RJ-45

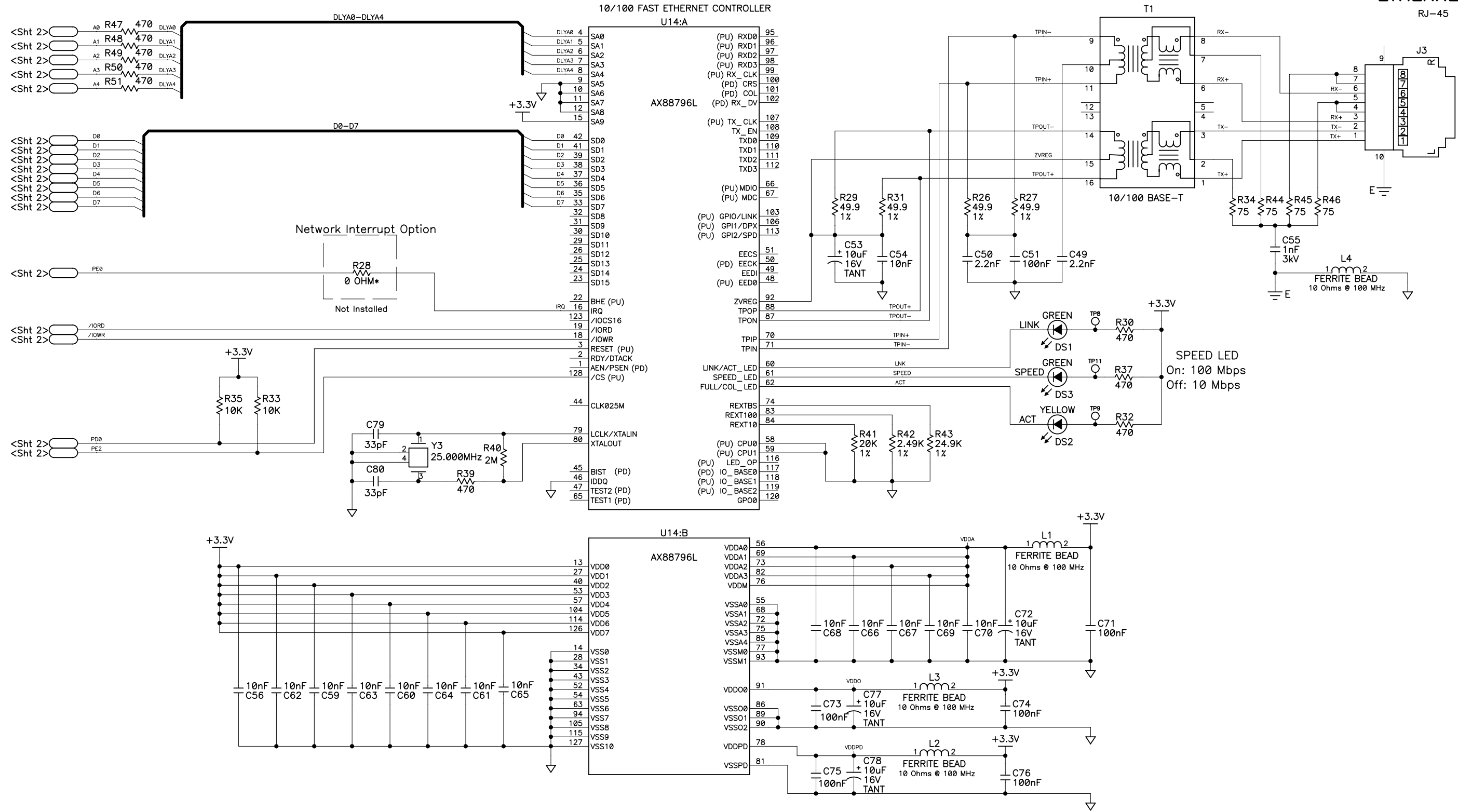

10/03/05

SIZE	DWG NO.
<b>B</b>	090-0210
SCALE	REV LTR
NONE	B
SHEET	OF
3	3

COPYRIGHT 2005, Z-WORLD, INC.