

REVISION HISTORY			REVISION APPROVAL			
REV	ECO	DESCRIPTION OF CHANGE	PROJECT ENGINEER	APPROVAL DATE	DOCUMENT CONTROL	APPROVAL DATE
A	E11764	INITIAL RELEASE. FOLLOWS REV C PCB.	JF	12DEC01	KIS	12DEC01
B	E11807	CHANGE VALUE OF RP2 & RP3; CORRECT J3 REFERENCE.	EP	1/16/02	KIS	1/16/02
C	E11990	RENAME TXC & TXC PINOUTS TO TXC/RTS & RXC/CTS.	EP	6/21/02	KIS	6/21/02
D	E13022	ADDED 20K POT(R4) FOR CONTRAST CONTROL. REMOVED R1. UPDATED RP2, RP3 VALUES AS IN REV. B AND COMPONENTS INSTALLED OPTION	XT	2/10/05	KF	2/9/05

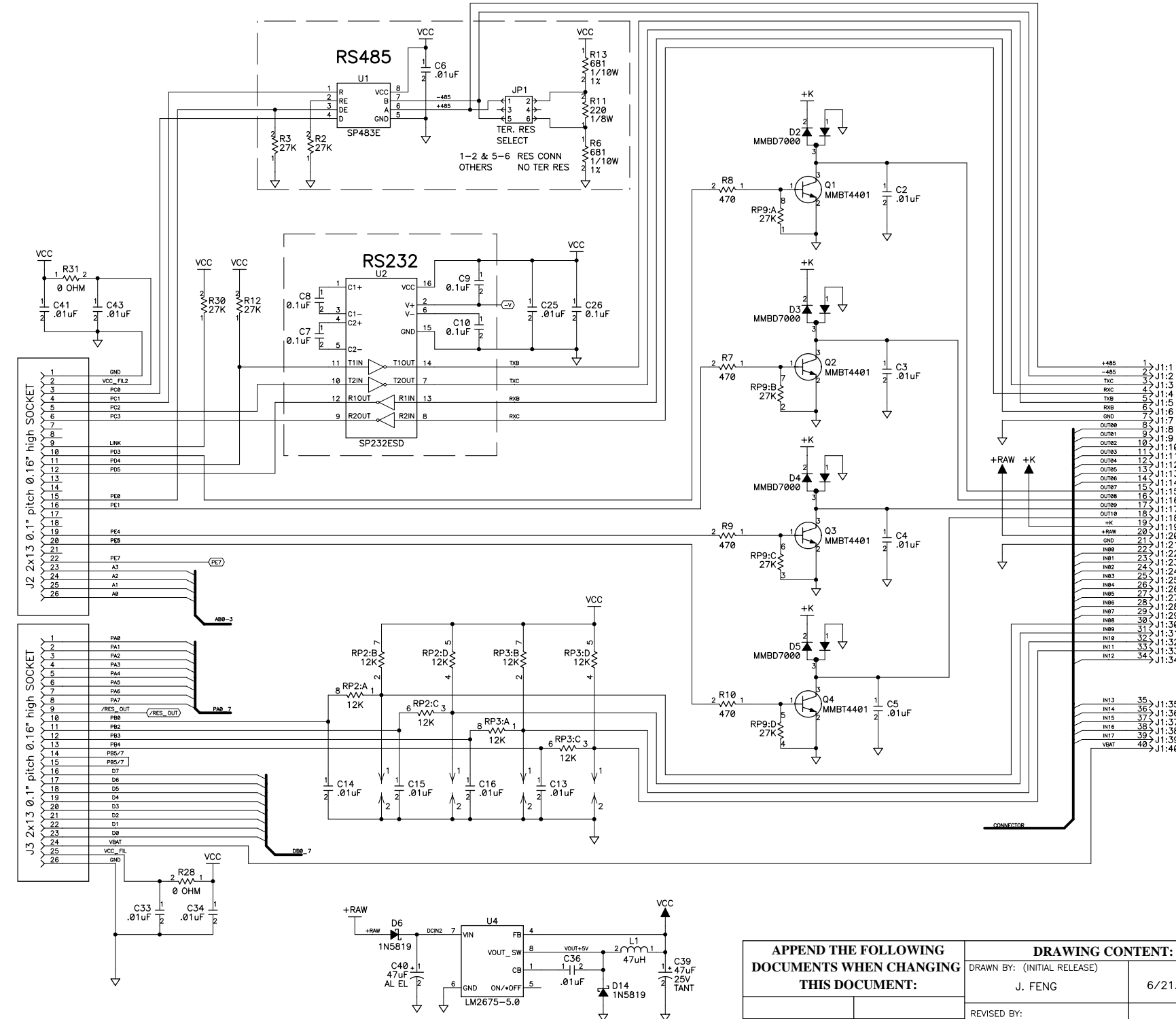

POWER TABLE

REF DES	DEVICE	DEVICE VOLTAGE		FILTER CAP
		VCC	GND	
U1	SP483EN	8	5	C6
U2	232A	16	15	C25, C26
U3	74VHC574	20	10	C35
U5	74VHC139	16	8	C38
U6	74VHC245	20	10	C37
U7	74VHC00	14	7	C42

- NOTES: UNLESS OTHERWISE SPECIFIED:
- ALL RESISTOR VALUES ARE IN OHMS, 1/16W, 5%
  - ALL CAPACITORS ARE 50VDC OR HIGHER.
  - THE ORIGIN SOURCE OF A VOLTAGE IS REPRESENTED BY (VCC), AND ALL REFERENCES TO THAT VOLTAGE ARE REPRESENTED BY (VCC).
  - COMPONENT VALUES SHOWN WITH AN ASTERISK (\*) FOLLOWING THE VALUE, MAY HAVE DIFFERENT VALUES, OR MAY NOT BE STUFFED.

To RabbitCore

APPEND THE FOLLOWING DOCUMENTS WHEN CHANGING THIS DOCUMENT:

DRAWING CONTENT:	
DRAWN BY: (INITIAL RELEASE)	J. FENG 6/21/02
REVISED BY:	XUAN TRUONG 12/28/05
APPROVALS: INITIAL RELEASE	
PROJECT ENGINEER:	J. FENG 12 DEC 01
ENGINEERING MANAGER:	D. MATTHEWS 12 DEC 01
SIGNATURES	DATE

TITLE: SCHEMATIC DIAGRAM OP6800 SERIES

2900 SPAFFORD ST. DAVIS, CA 95616 530 - 757-4616

SIZE: **C** DWG NO. **090-0134**

SCALE: NONE RELEASE DATE: 12 DEC 01 SHEET 1 OF 2

